

# Owner's Manual

---

## *607 PRO Challenger Series Rotary Vane Vacuum Pumps*

---



Visit our web site to download pump setup guides,  
brochures and other technical information.



# 607 PRO Challenger

## Owner's Record

**Date of Purchase:** \_\_\_\_\_

**Purchased from:** \_\_\_\_\_

**Serial Number:** \_\_\_\_\_

© 2015 National Vacuum Equipment, Inc.  
Revision: 2 (Released) September, 2015

*No part of this manual may be reproduced without the written permission of  
National Vacuum Equipment, Inc.*

# IMPORTANT INFORMATION FOR INSTALLING PUMP

607 PRO CHALLENGER SERIES PUMPS AERIAL VIEW

SHADED AREA MUST BE KEPT CLEAR  
FOR SERVICING THE FILTER

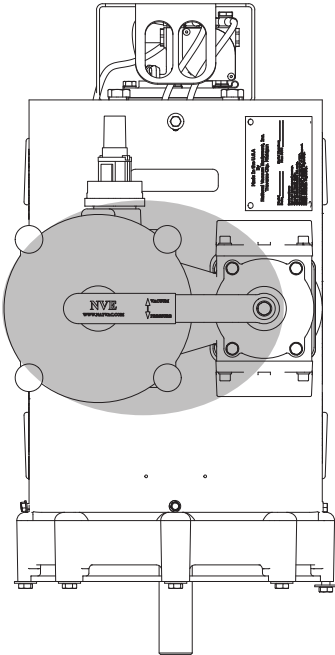

Counter Clockwise  
Rotation

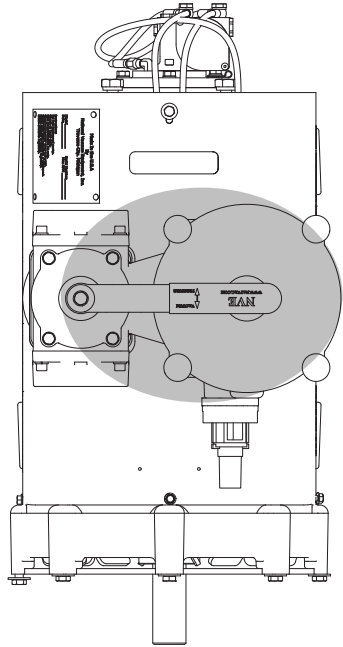

Clockwise  
Rotation

# Contents

<b>Introduction</b>	<b>5</b>
General Information.....	5
<b>Limited Warranty</b>	<b>6</b>
Warranty.....	6
<b>607 PRO Challenger</b>	<b>9</b>
Application.....	9
Pump Specifications.....	9
System Requirements.....	10
Drive System.....	11
Factory Settings.....	11
Adjusting Factory Oil Settings.....	12
<b>Operating Instructions</b>	<b>14</b>
Normal Operation.....	14
Recommended Lubricant.....	15
Maintenance.....	16
Cold Weather Operation.....	17
<b>Troubleshooting</b>	<b>18</b>
Pump overheats.....	18
Pump uses too much oil.....	18
Pump doesn't turn.....	18
No vacuum.....	19
System Troubleshooting.....	19
Making a vacuum tester.....	20
<b>Parts Breakdown</b>	<b>21</b>
607 PRO Fan Cooled Parts Diagram.....	21
607 PRO Liquid Cooled Parts Diagram.....	22
607 PRO SV Parts Diagram.....	23
607 PRO Challenger Series Vacuum Pumps Parts List.....	24
607 PRO Fan Cooled Parts Oil Line Routing.....	26
607 PRO Liquid Cooled Oil Line Routing.....	27
<b>Vane Replacement &amp; Complete Rebuild Manual</b>	<b>29</b>
607 PRO Liquid and Fan Cooled Vane Replacement.....	30
607 PRO Liquid and Fan Cooled Complete Rebuild.....	34

# Introduction

## General Information



### About National Vacuum Equipment

**Congratulations!** You now own a quality vacuum/pressure pump proudly manufactured in the U.S.A. by National Vacuum Equipment, Inc. You have not only acquired a superior piece of equipment from a qualified dealer, you have hired a team of vacuum experts. We stand ready to work with your dealer to answer your questions and provide you with the information necessary to keep your equipment in peak working condition.

Thank you for putting your trust in National Vacuum Equipment.

### Our Mission

We are dedicated to the production and wholesale distribution of quality vacuum system products at a reasonable price, on a timely basis. We are a “one-stop shop” for manufacturers and distributors of vacuum equipment.

### Our History

National Vacuum Equipment, Inc. was founded in 1980 by Bruce Luoma. The Company started as a retailer of vacuum pumps. Soon after it started, the Company secured the rights to exclusive distribution of the Battioni vacuum pumps in North America. This helped the Company to evolve into its current status as a wholesale supplier.

To reach the goal of becoming a full service supplier of vacuum system components, the Company began fabrication of its own line of components, purchased and developed its own line of vacuum pumps, and began purchasing for resale, various valves and accessories.

Today, NVE has full service machine, fabrication and powder-coating shops complete with CNC-controlled production equipment designed for close tolerance work. The company has a highly trained staff, all of whom are dedicated to quality.

# Limited Warranty

## 607 PRO Challenger



---

## Warranty

### National Vacuum Equipment, Inc.

Guarantees that the product it provides is free of manufacturer's defects, including materials and workmanship. When properly installed and maintained this product is warranted for a period of two (2) years subject to the following conditions:

1. A properly completed warranty registration card must be received by us within 30 days of sale to end user for pump sales to be considered warrantable. All pumps received for warranty consideration must retain the original NVE serial number tag.
2. The two (2) year period shall begin the day the product is shipped from our warehouse, unless we are provided with an authentic copy of the original resale invoice, in which case the two (2) year period shall begin at such invoice date.
3. The covered product must be used in an application for which it was intended. We do not recommend our product for particular uses or applications.
4. Vane breakage, or damage caused by vane breakage, is not warrantable.
5. Damage caused by improper use or lack of proper maintenance is not warrantable.
6. Manufacturer's liability under this or any other warranty, whether express or implied, is limited to repair of or, at the manufacturer's option, replacement of parts which are shown to have been defective when shipped

7. Manufacturer's liability shall not be enforceable for any product until National Vacuum Equipment, Inc. has been paid in full for such product.
8. Except to the extent expressly stated herein, manufacturer's liability for incidental and consequential damage is hereby excluded to the full extent permitted by law.
9. Manufacturer's liability as stated herein cannot be altered except in writing signed by an officer of National Vacuum Equipment, Inc.
10. Certain products provided by National Vacuum Equipment, Inc. are covered by their respective manufacturer's warranties (e.g., engines used in the NVE engine drive packages). These products are not covered by the National Vacuum Equipment, Inc. Manufacturer's Warranty.
11. Final assemblers responsibility. NVE goes to great lengths to insure the quality and proper functionality of the products it supplies. Many products we supply are purchased for resale or are impossible or impractical to test prior to the installation of the item in a vacuum system. It is therefore the responsibility of the final assembler to thoroughly test the vacuum system and components supplied to the assembler by NVE prior to the delivery of the final product to the end user.
12. NVE is not responsible for pump coupling tightness or alignment. Customer needs to inspect periodically to ensure proper alignment and to check tightness of set screws.

Any items found to be defective after delivery to the end user that should have been discovered prior to delivery will qualify for replacement of the defective part only with absolutely no compensation for outside labor or travel expenses. Any subsequent damage to other components caused by the defective part will be the sole responsibility of the assembler.

---

## Warranty Procedures

### **Should a potential warranty situation arise, the following procedures must be followed:**

- Contact your dealer or NVE immediately upon the occurrence of the event and within the warranty period.
- Customer must receive a return materials authorization (RMA) form from NVE before returning product.
- All serial-numbered products must retain the original NVE serial number tag to be qualified for warranty.
- Product must be returned to NVE intact for inspection before warranty will be honored.
- Product must be returned to NVE freight prepaid in the most economical way.
- Credit will be issued for material found to be defective upon our inspection, based upon prices at the time of purchase.



# 607 PRO Challenger

## Model-Specific Information



---

## Application

### Designed for extended operation

- Duty cycle will vary depending on several factors, such as altitude, RPM & ambient temperature.
- The 607 PRO Challenger is a heavy duty vacuum pump, designed to be used in liquid waste pumping systems where extended operation is desired.
- Proven applications are:
  - Oil field
  - Septic
  - Restaurant Grease
  - Industrial Waste

---

## Pump Specifications

### 607 PRO Calculated Flow Data

RPM		Pressure (PSI)				Free flow	Vacuum (inches of Mercury)					
		20	15	10	5	0	5	10	15	20	25	27
1500	Hp.	34	32	29	27	23	23	22	21	20	19	19
	CFM	282	291	301	331	380	348	338	331	310	282	244
1250	Hp.	29	27	24	23	20	20	19	16	15	14	14
	CFM	229	237	244	269	320	282	275	269	252	229	198
1000	Hp.	25	23	20	18	15	15	14	14	13	12	12
	CFM	178	184	190	209	245	220	214	209	196	178	155

Recommended RPM 1000-1250  
 maximum of 1500 RPM is for intermittent operation only.

---

## System Requirements

### High Quality Components

- The 607 PRO Challenger is a high performance vacuum pump and requires compatible, high quality components as manufactured by NVE.

### Shutoffs

- We recommend an 8" cage and a 6" stainless steel ball which is standard in all of our primary and secondary shutoffs.

### Hose

- Use 3" or larger hose to plumb your system. We recommend you use a hose that can withstand high temperatures such as hot tar-asphalt hose.

### Pressure and Vacuum Relief Valves

- A properly adjusted pressure relief and vacuum relief valves should also be incorporated in the system between the secondary shutoff and the pump.
- The relief valves should be set to where the pump operates at a maximum temperature of 375 degrees Fahrenheit.

---

## Pressure and Vacuum Relief Valve Setting Instructions

### Pressure Relief Valve

Picture 1.

1. Unscrew the lock nut "A"
2. Turn the spring-tightener "B"

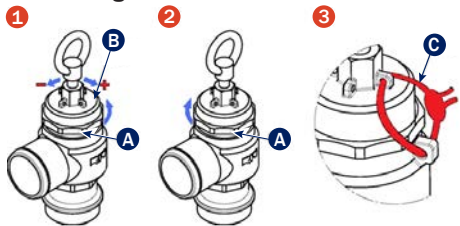

Picture 2.

1. Once obtained the desired pressure, screw down the lock nut "A"

Picture 3.

1. Fix the setting, using the rings "C" Situated on the body and on the spring tightener

### Vacuum Relief Valve

1. Remove the protection cap "A"

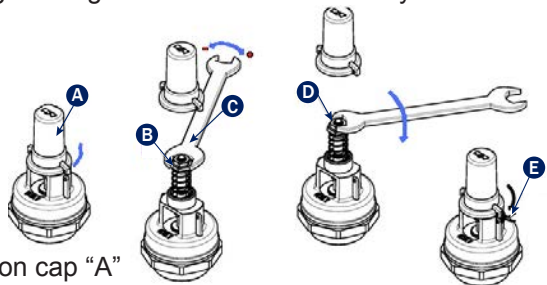

---

## **Vacuum Relief Valve *Continued***

2. Turn the spring-tighter “B”, through a spanner “C”, clockwise to increase the pressure, counter-clockwise to reduce the pressure
3. Once obtained the desired pressure, screw down the lock nut “D”
4. Screw down the protection cap and fix it using the rings “E” situated on the valve body and on the cap

---

## **Drive System**

- The pump should be mounted on a level, horizontal surface, secured with grade 8 fasteners.
- The drive system should be sized to supply the required horsepower to the pump plus a reserve to insure long life.
- The power take off (PTO) must be slowly engaged or it will damage the pump and drive components.
- Make certain that all shafts, pulleys or turning parts are properly guarded.
- Check the ratio of the drive system prior to installation to verify that the pump will be turning at the proper speed.

---

## **Direction of Rotation**

- The direction of rotation and RPM are marked on the front of the pump.
- The direction of rotation required by your drive system should be determined prior to ordering the pump. Please pay special attention to the orientation of the final filter, which varies with rotation.

---

## **Factory Settings**

- The automatic lubrication pumps are set at the factory during pump testing and should require no further adjustment during pump installation. The oil pump is easily adjustable from 5-24 ounces per hour.
- It is the responsibility of the installer to ensure proper vacuum and pressure settings and RPM.

## Oil Pump Flow Rate Adjustment Procedures

1. Remove oil pump cap (3/32 hex).  
Ensure o-ring stays intact.

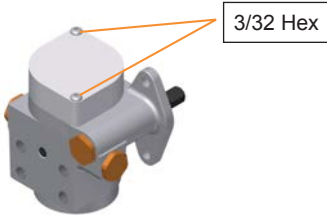

2. Move cam so adjustment screws are resting on lower flats

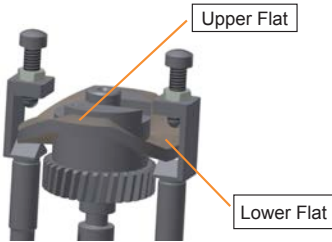

3. Hold adjustment screw (9/64 hex or flat head screw) while loosening jam nut (1/4" wrench). Spin jam nut all the way up to the head.

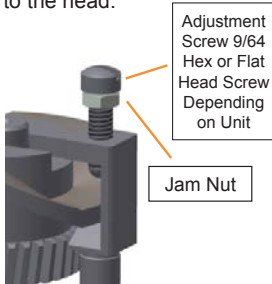

4. Tighten adjustment screw (CW) until it seats on the cam. (Do not force!)

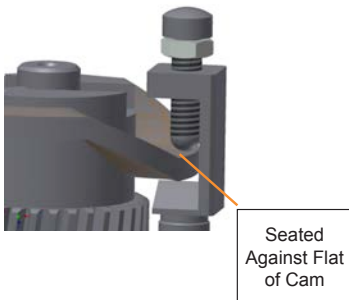

5. Back the screw off the desired amount of turns (CCW).

Tip: More turns out equals less oil flow.  
Fewer turns out equals more oil flow.

6. Retighten jam nut while holding adjustment screw.

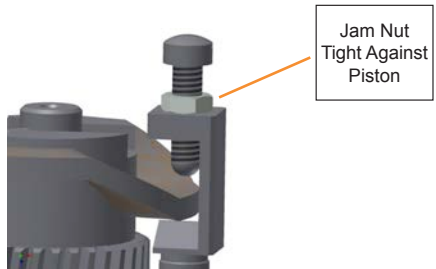

7. Repeat process for other adjustment screw.

8. Reassemble cover onto pump assuring o-ring does not fall out of groove, and springs are located over adjustment screws

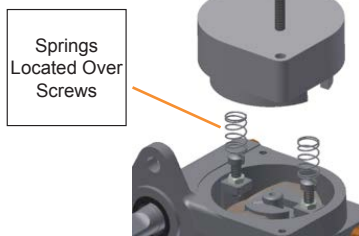
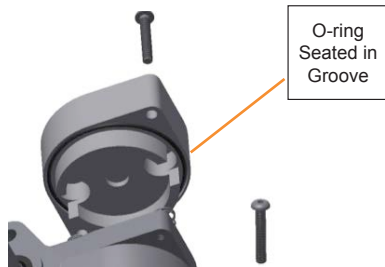

If oil pump requires further adjustment, the rule is 1/2 turn CW = 1 oz/hr higher oil flow.

**Adjusting Factory Oil Settings *Continued***

**NVE 4 Port Oil Pump Adjustment Rate Chart  
Tested at 1100 RPM**

Turns From Bottom	Ounces Per Hour
7.5	6
7.25	7
7	8
6.75	9
6.5	10
6	11
5.5	12
5	13
4.75	14
4.5	15
4.25	16

# Operating Instructions

## 607 PRO Challenger



---

### Normal Operation

#### Oil Reservoir

- Check oil reservoir daily and fill as required.
- Drain and clean periodically depending on use.

#### Temperature

- Check exhaust temperature. It must not exceed 375 degrees Fahrenheit at any time.

#### Recommended RPM

- Do not operate the pump faster than the recommended RPM of 1000-1250. 1500 RPM is for intermittent use only.
- Too low of an RPM can cause the vanes to clatter (inconsistent contact with the housing) causing wear.

#### Suction Valve

- To operate the suction valve, move the handle in the appropriate direction for either vacuum or pressure; center is neutral.

#### Vacuum Levels

- Do not operate your pump for extended periods of time at vacuum levels which cause the pump to exceed 375 degrees Fahrenheit exhaust gas temperature.

#### Guards

- Make certain all guards are in place prior to running your pump. Think Safety!

---

## Recommended Lubricant

Recommended NVE Turbine Oils:

1. \*NVE ISO 68 Oil (Winter Blend)
2. \*NVE ISO 150 Oil (Summer Blend)

Other Acceptable Turbine Oils:

1. Shell Turbo 68
2. Mobil D.T.E. Heavy - Medium
3. Texaco Regal R & O 68
4. Chevron GST
5. Penzobill Penzabell 68 T.O.

*\* NVE ISO 68 and NVE ISO 150 Oils are recommended for the Challenger series vacuum pumps. Challenger Vacuum Pump Oil is sold by the case, (6) gallons per case.*

Although we recommended using a turbine oil for optimum use, you may use any type of oil you prefer, as long as you monitor your operating temperatures and keep your pump within the proper operating range (must not exceed 375 degrees). Using a non-turbine oil outside of the recommended range may cause problems such as overheating, lacquering and excessive wear, which can lead to severe damage to your equipment.

---

## Maintenance

### Washing

- Periodically wash the mud and dirt off of your pump as it must be clean to allow heat to radiate from it.

### Flushing

We recommend periodic flushing of your pump. To do this:

1. Connect the hose to the flush valve located on the side of the inlet port.
2. Put the end of the hose in a one pint container of diesel fuel. Start your pump and run as slow as possible.
3. With the suction valve in the vacuum position, monitor the diesel flow to your pump.
4. When the diesel fuel is gone, switch the suction valve to neutral and run the pump for 2 minutes.
5. Speed the pump up to normal RPM, switch the suction valve to vacuum.
6. Remove the hose and close the valve.
7. Properly dispose of used oil and flushing fluid.

### Checking Vane Wear

- We recommend checking vane wear at least once every 12 months.
- A new vane is flush with the outside diameter of the rotor.
- Remove the plug from the vane check port, insert a rod into the rotor's outside diameter, rotate rotor until the rod falls into one of the vane slots. If the rod falls more than a 1/4" into any of the 7 vane slots, it's time to replace the vanes.
- Vanes should be replaced in sets and it is always a good idea to have an extra set of vanes on hand for emergencies.



---

## Maintenance *Continued*

- Check filter regularly
- Clean filter with compressed air or a cleaning solution.  
*The filter is made of stainless steel, please keep that in mind when choosing your cleaning solution.*
- Before reinserting the filter into the housing, lube the inside end of the filter that will fit over the lip in the bottom of the housing.

*Properly apply lube here on the inside lip of the filter...*

*...before reinserting here.*

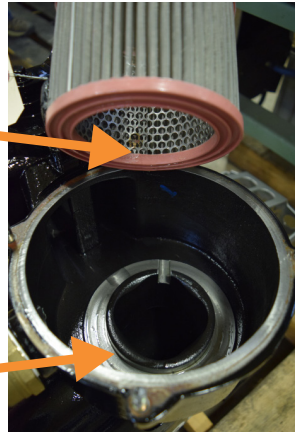

## Cold Weather Operation

### **Prior to engaging pump.**

- Confirm pump is not frozen.

### **If pump is frozen, thaw it.**

- If the pump is frozen, thaw it out by moving the truck into a heated building.

### **Avoid freezing problems**

- You can avoid freezing problems by putting a small amount of diesel fuel into the pump at the end of the day.

# Troubleshooting

## NVE 607 PRO Vacuum Pump



---

### Problem: Pump overheats

#### Causes:

- No oil in pump
- Oil adjustment set too lean
- RPM too fast
- Prolonged operation at excessive vacuum or pressure levels
- Pump is dirty
- Inlet filter is clogged.

---

### Problem: Pump uses too much oil

#### Causes:

- Oil pump set too rich
- Leaving pump under vacuum between jobs
- Product running through pump

---

### Problem: Pump doesn't turn

#### Causes:

- Broken vane or bearing
- Pump is frozen
- Problem in the drive train

---

## **Problem: No vacuum**

### **Causes:**

- Suction valve is in neutral
- Worn seals or vanes
- Pump is not turning fast enough
- Check valve or suction valve is clogged
- Leak in the tank or fittings
- Collapsed hose between the pump and shutoffs
- Inlet filter clogged

## **System Troubleshooting**

### **Locating the source of the trouble**

If you notice a decrease in pump performance, start troubleshooting at the pump.

- Remove the suction and discharge hoses at the pump.
- Start the pump and run it in vacuum only at its normal RPM
- Check the vacuum level at the pump inlet. The 607 PRO Challenger in new condition will develop 27-28.5" hg.
- If the pump checks out ok, check the vacuum level at the secondary, then the primary shutoff. Keep working your way back until you find the problem.

**For rebuild instructions, go to page 34 of this manual.**

**You may also visit our website at [www.natvac.com](http://www.natvac.com) or call us at 800-253-5500**

---

## **Making a vacuum tester**

1. Procure a flange to mount on your 4-way valve, a short 3" pipe nipple, a 3" pipe cap and a vacuum gage.
2. Drill and tap a 1/4" N.P.T. thread in the pipe cap.
3. Assemble the flange, nipple, pipe cap and vacuum gage.
4. Remove a flange from the four-way valve on your pump.
5. Start the pump and confirm the location you have chosen to test from is at vacuum.
6. Using the existing O-ring, fasten the testing flange to your pump.
7. Start your pump and read the vacuum level on the gauge.

# NVE 607 PRO Challenger Fan Cooled | Parts Diagram

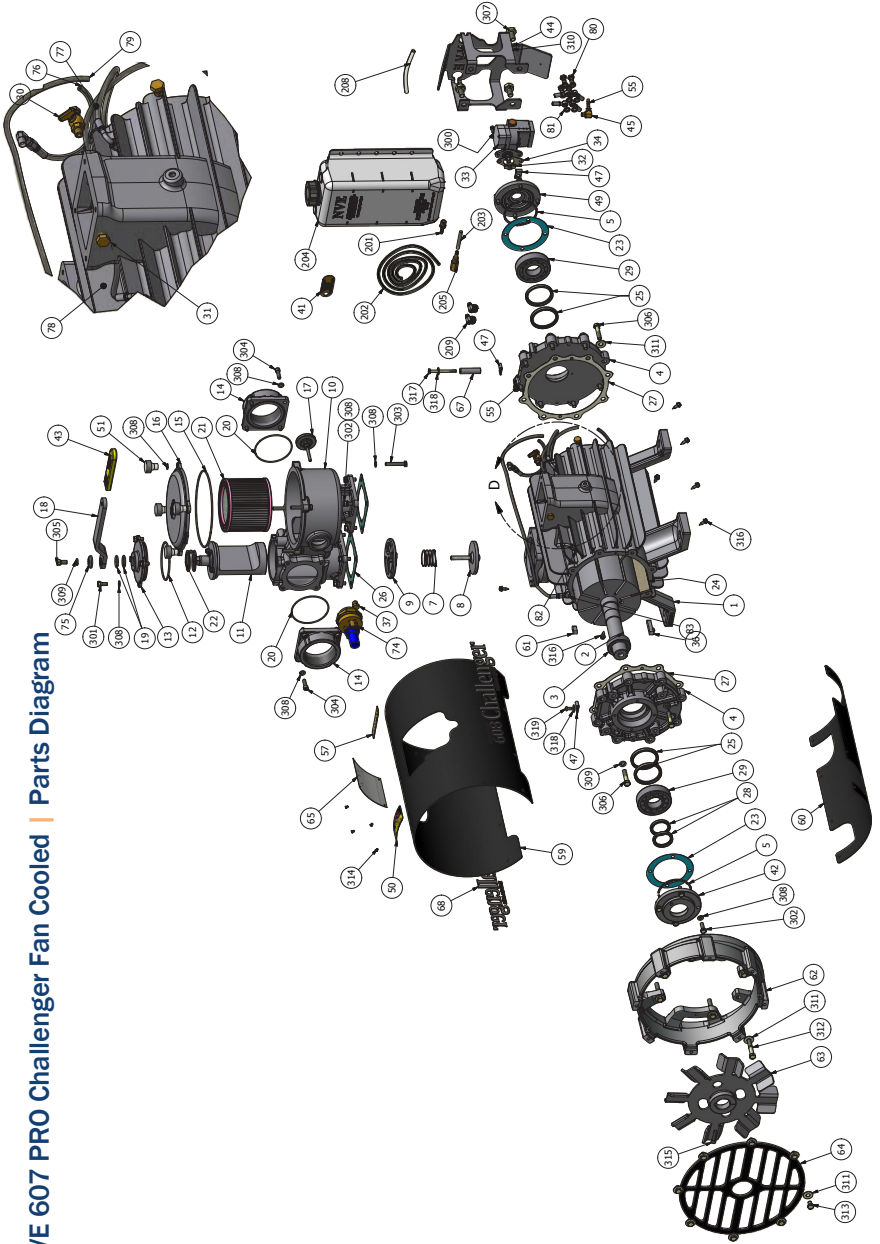

NVE 607 PRO Challenger Liquid Cooled | Parts Diagram

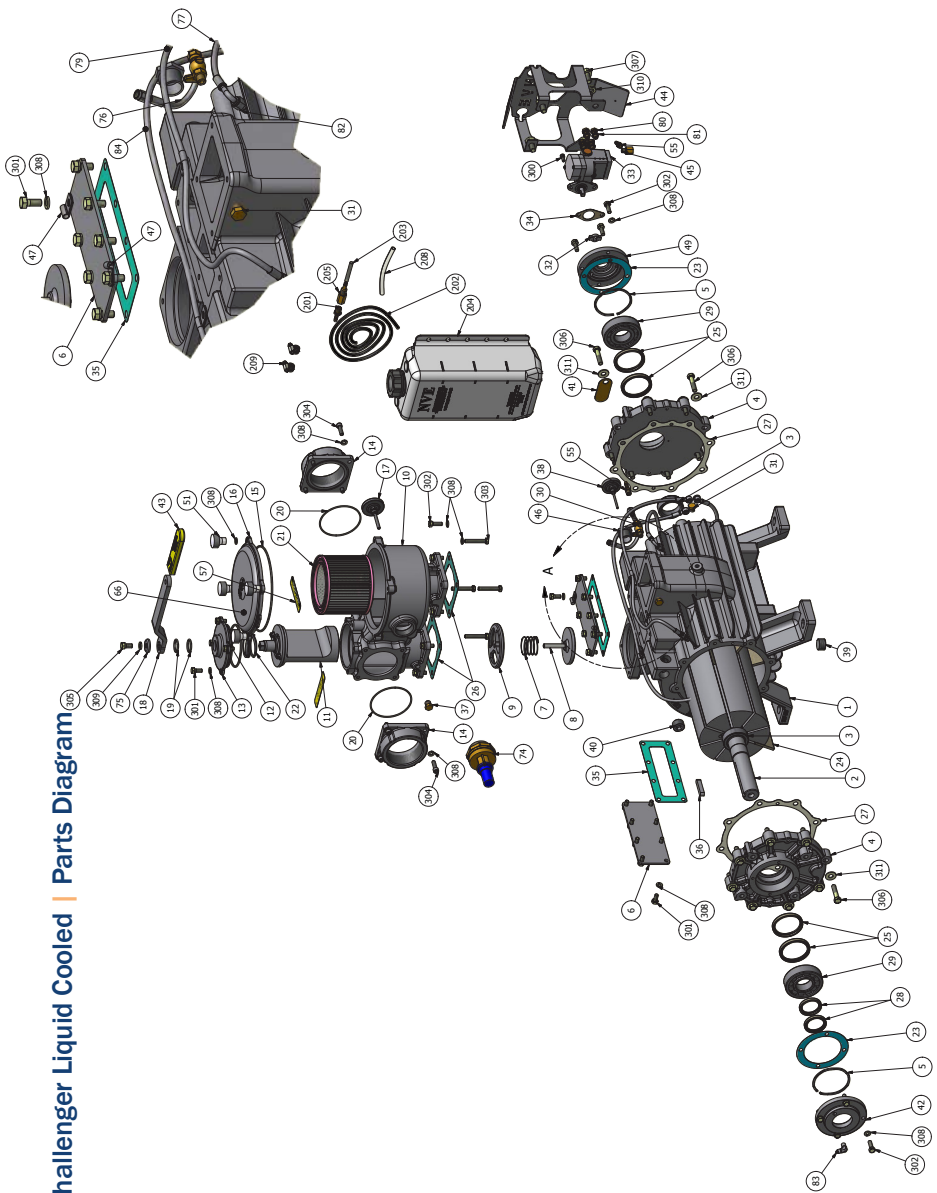

NVE 607 PRO SV Challenger Fan Cooled | Parts Diagram

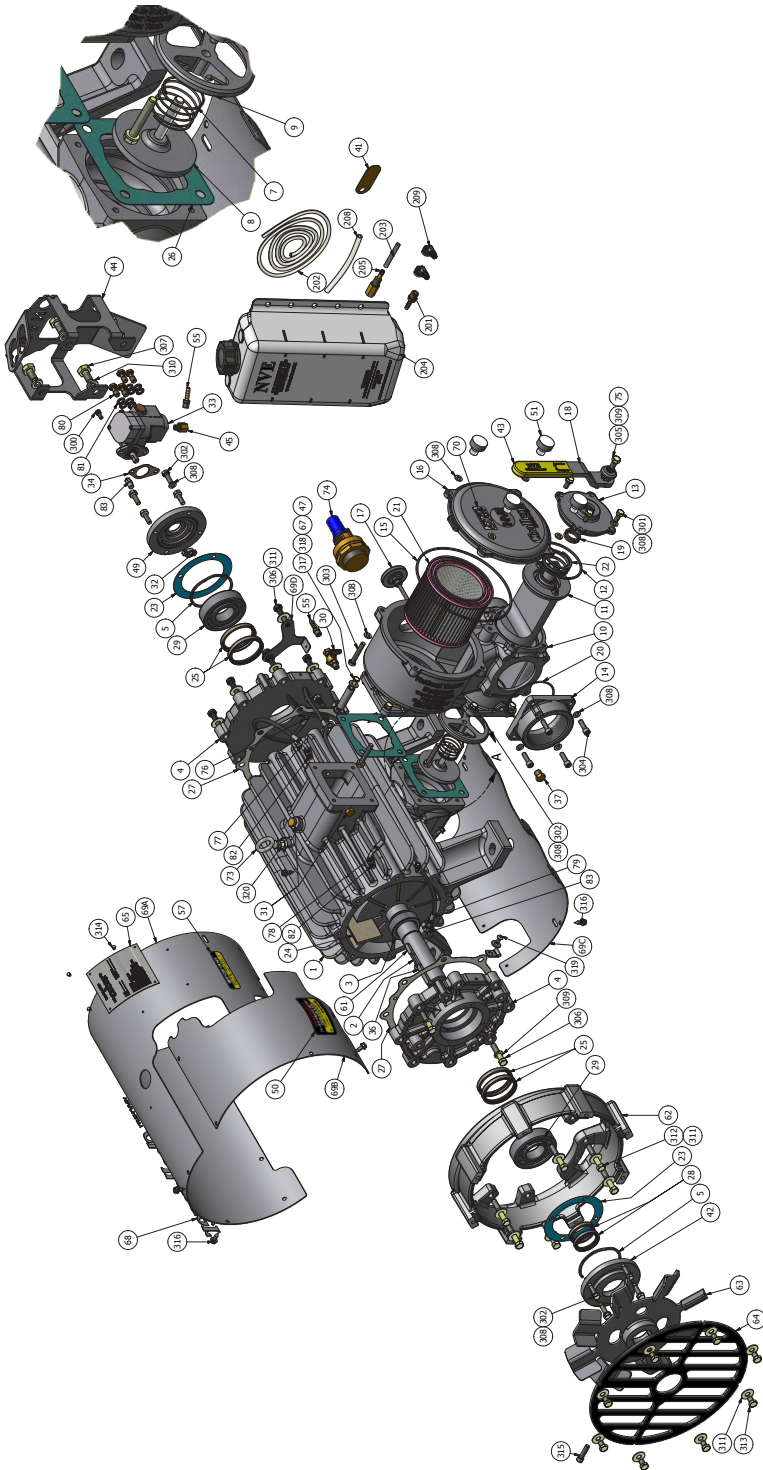

## NVE 607 PRO Challenger Series | Parts List

ITEM	PART NUMBER	DESCRIPTION
1	120-001-367 120-001-367-L 120-001-607A	HOUSING FAN HOUSING LIQUID HOUSING SIDE VALVE
2	120-005-367	ROTOR 607
3	120-009-367	SEAL SLEEVE
4	120-003-001	ENDPLATE 607
5	120-045-001	SPRING WAVE WIRE 3.5" DIA
6	120-021-367	COVER PLATE WATER JACKET
7	120-046-367	SPRING CHECK VALVE
8	120-041-367	CHECK VALVE 3"
9	120-042-367	RETAINER RING CHECK VALVE 3"
10	120-320-003	HOUSING FILTER WITH RELIEF BOSS
11	120-062-002	PLUG 4-WAY FOR 3/8" HANDLE
12	120-064-003	O-RING 2-240 VITON
13	120-065-002	TOWER MACHINED 3"
14	120-063-367	FLANGE 4-WAY 3" NPT
15	120-064-004	O-RING 2-265 VITON
16	120-310-001	COVER FILTER
17	120-220	THERMOMETER, 50-400 DEG, 2" FOR PUMPS FACE 2.5"
18	120-060-006	HANDLE 3/8"
19	120-064-002	O-RING 2-214 VITON
20	120-064-001	O-RING 2-154-VITON
21	120-314-001	FILTER ELEMENT INLET
22	120-045	SPRING 4-WAY FILTER VALVE
23	120-055-367	GASKET BEARINGS COVER FRONT
24	120-007-367	VANE
25	120-018-367	SEAK 60 X 72 X 8 AV VITON SGL LIP RUBBER COATED
26	120-039-367	GASKET INTAKE/EXHAUST GARLOCK
27	120-004-367	GASKET ENDPLATE 0.006" VEG
28	120-053	SEAL 40 X 52 X 7 VITON
29	120-019-367	BEARING NJ308 L1308B
30	120-102	DRAIN VALVE 1/8" NPT
31	120-058	PLUG BRASS HEX HEAD 0.125" NPT
32	320-LF8	DRIVE TAB
33	123-000-002	OIL PUMP 4 PORT BI-DIRECTIONAL
34	320-R31	GASKET OIL PUMP
35	120-022-367	GASKET COVER PLATE
36	120-006	KEY 0.375" X 0.375" X2" 1018 UN BER
37	120-059	PLUG BRASS HEX HEAD 0.25" NPT
38	120-220-1	THERMOMETER 220F WPT 0.125"-27 NPT
39	120-047-1	DRAIN PLUG 3/4" NPT SOC HD MAGNETIC
40	120-047	DRAIN PLUG 3/4" NPT
41	120-107	TAG SERIAL NUMBER BRASS
42	120-054-001	BEARING COVER
43	120-060-005	GRIP 3/8" HANDLE W/ LOGO
44	120-079-005	GUARD NVE OIL PUMP



**NVE 607 PRO Challenger Series | Parts List *Continued***

ITEM	PART NUMBER	DESCRIPTION
45	320-408-001	ADAPTER ELBOW 1/8" BSPT-NPT
46	120-049	BUSHING 0.75" NOT X 0.125"-27 NPT
47	320-409-003	P-CLIP OIL LINE 1/4" X 5/16"
49	120-054-002	BEARING COVER OIL PUMP MOUNT
50	120-101-367-D 120-101-367-S	DECAL 607 PRO FAN CW DECAL 607 PRO FAN CCW
51	120-312-002	KNOB FILTER COVER 5/16-18 UN
55	310-LP5	HOSE BARB 1/4" X 1/8" NPT STRAIGHT
57	120-103-367	DECAL IMPORTANT 375 DEGREES
59	120-071-367-D 120-071-367-S	SHROUD UPPER CW SHROUD UPPER CCW
60	120-070-367-DS	SHROUD LOWER ROLLED
61	120-076	KEY FAN 0.375" X 0.375" X 1" ROUND BOTH ENDS 1018 UN BER
62	120-074-001	FAN SHROUD
63	120-083-002 120-083-001	FAN ASSY CW FAN ASSY CCW
64	120-073-E	FAN COVER E-COAT
65	120-105	TAG NVE SERIAL NUMBER LARGE
66	120-106-367-D 120-106-367-S	DECAL CW LIQUID DECAL CCW LIQUID
67	120-077-367	SHROUD SUPPORT 0.5625" X 2.125"
68	120-100-607	DECAL 607 PRO CHALLENGER HEAVY DUTY
69A	120-071-607A-S	TIN SET CCW
70	120-100-608A	DECAL CHALLENGER 607 SIDE MANIFOLD
73	120-351-001	LIFT EYE 3/8-16 PLATED
74	366-150	VACUUM RELIEF 1 1/2" NPT
75	412-020-001	WASHER, CUP 4-WAY VALVE 3/8" HANDLE
76	320-407-005	OIL LINE -3 SST FEMALE JIC TO BANJO 6.75"
77	320-407-006	OIL LINE -3 SST 90 DEG JIC TO BANJO 17.5"
78	320-407-008	OIL LINE -3 SST 90 DEG JIC TO BANJO 24.5"
79	320-407-007	OIL LINE -3 SST FEMALE JIC TO BANJO 30.75"
80	123-408-014	BANJO BOLT 1/8" BSPP
81	123-013-001	WASHER 3/8" SEALING NBR
82	320-408-016	FITTING STR -3 MJIC X 1/8 MNPT
83	320-408-017	FITTING ELBOW -3 MJIC X 1/8 MNPT
84	320-407-014	OIL LINE -3 SST FEMALE JIC TO BANJO 34.00"
201	310-LP6	HOSE BARB 1/4" NPT X 1/4" STRAIGHT
202	320-407-003	OIL LINE BLACK 1/4" ID 30R7
203	320-083-009	OIL TANK FILTER 100 MESH
204	320-082-001	OIL TANK 5QT & TETHERED CAP BLACK
205	320-083-010	FILTER FITTING OIL TANK 1/4 NPT
208	320-R102	OIL LINE 3/8" X 1/4" ID LINE
209	416-025-1WC	CLAMP WORM 1/4" SS

# 607 PRO Challenger - Fan Cooled - Oil Line Routing

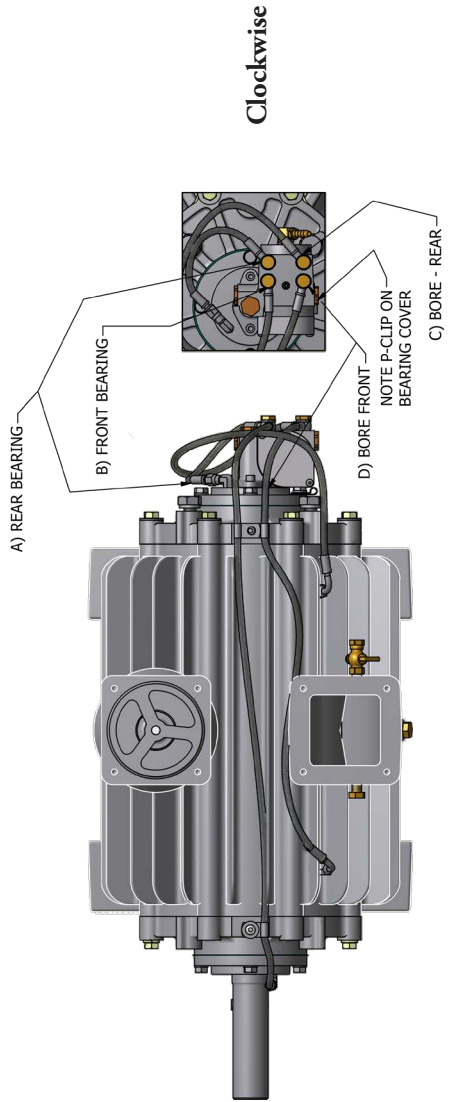
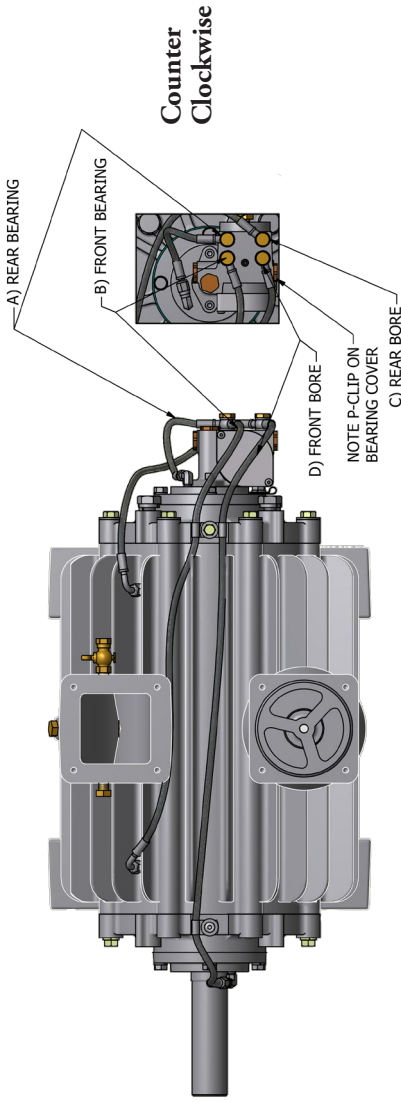

# 607 PRO Challenger - Liquid Cooled - Oil Line Routing

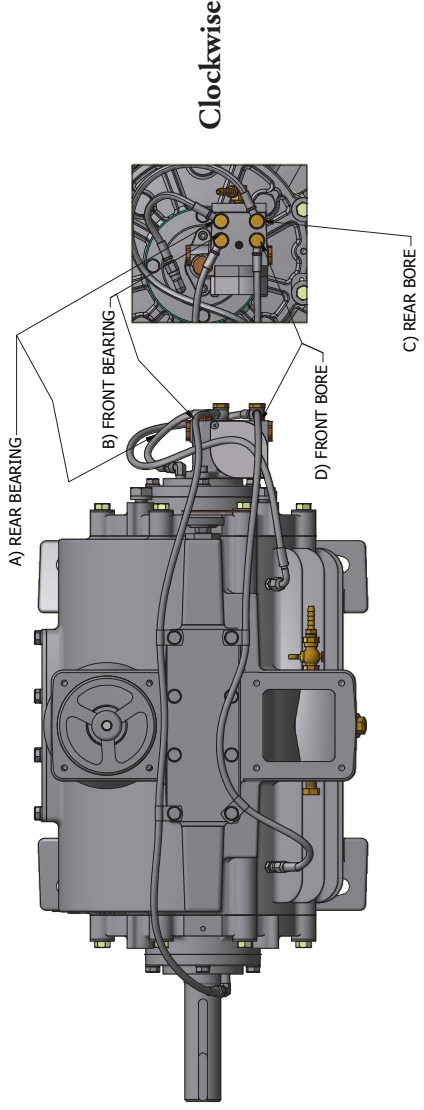
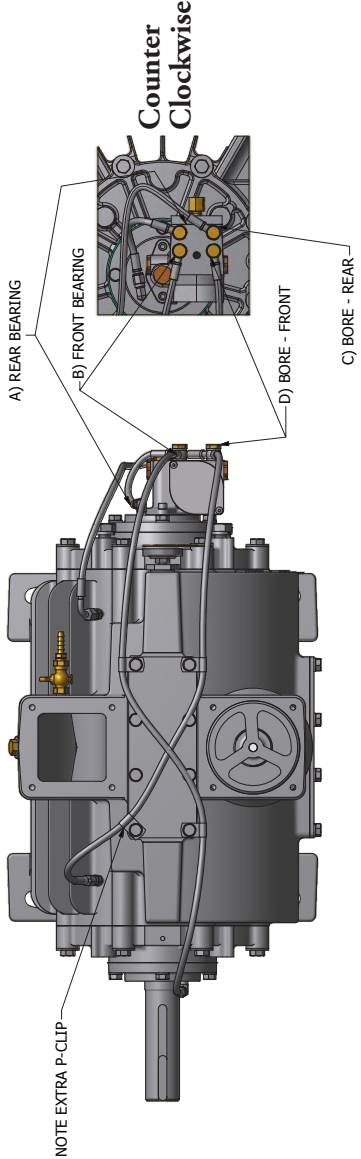



# Vane Replacement & Complete Rebuild Manual

*Challenger Series Rotary Vane Vacuum Pumps*



# Vane Replacement

## 607 PRO Fan and Liquid Cooled

Also note that you can visit:  
[natvac.com/vane-replacement](http://natvac.com/vane-replacement)  
to view a step by step video  
walkthrough with instructions on  
vane replacement and maintenance.



1. Clean off the exterior of the pump

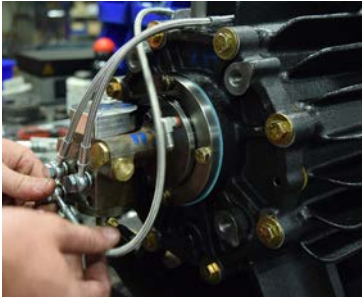

2. Remove the oil pump guard.  
Disconnect all oil lines feeding  
from the oil pump

Uninstall the oil pump from the  
rear bearing cover.

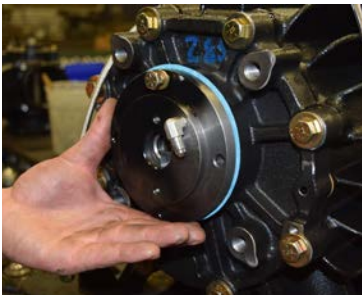

3. Remove the four (4) bolts that  
hold the rear bearing cover to  
the rear endplate and note that  
the wave spring seal is to be  
re-used.



4. Remove the oil pump drive key from the end of the rotor.



5. (Fan Cooled Only)  
Remove the fan shroud supports connecting the shroud "tin" to the rear endplate.



6. Remove the endplate bolts.



7. Remove the rear endplate with a gentle "wiggle", clean gasket surface and remove the vanes for inspection.



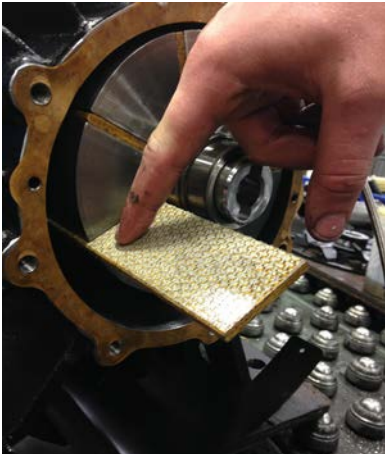

8. Inspect the original vanes for any delamination, chipping or other damage.

If any of the vanes are worn more than 1/4", are chipped or delaminated they should be replaced.

We highly recommend replacing vanes in sets. Apply a liberal amount of lubricant to the vanes before installing in the rotor slots.

It is always a good idea to have a spare set of replacement vanes on hand to reduce pump downtime.



9. Install one (1) new endplate gasket between the housing and the endplate, **do not use any gasket sealer.**

Carefully guide the endplate onto the rotor





10. Insert the two (2) "T-handle" pins provided in your rebuild kit through the endplate and into the locator holes at 3 and 6 O'clock positions on the housing.

Snug the endplate close to the housing.

**(Liquid Cooled Only)** The 3/8 hex bolts located on the water jacket side of the pump housing need to have high temperature (Red) RTV Silicone re-applied.

Install the hex head bolts.

Reseat the outer bearing in the endplate pilot.

Tighten the endplate bolts to 35-40 ft-lbs of torque.

**(Fan Cooled Only)** Reinstall the self-tapping screws for holding the fan shroud)

At this point you should be able to turn the rotor by hand.

11. Reinstall the oil pump drive key in the rotor.

Reinstall the oil pump / rear bearing cover. Ensure the oil pump shaft is aligned with the drive key.

Reconnect the oil lines to the oil pump, (Do not overtighten fittings)

Reconnect the pump to its oil reservoir and start at a slow R.P.M.



# Complete Rebuild

## 607 PRO Fan and Liquid Cooled

Also note that you can visit: [natvac.com/vane-replacement](http://natvac.com/vane-replacement) to view a step by step video walkthrough with instructions on vane replacement and maintenance.



1. Clean off the exterior of the pump

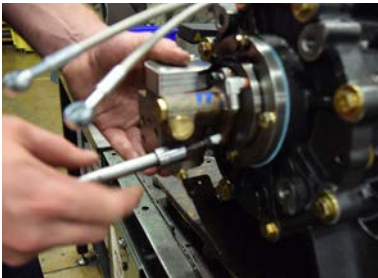

2. Remove the oil pump guard.  
Disconnect all oil lines feeding from the oil pump

Uninstall the oil pump from the rear bearing cover.

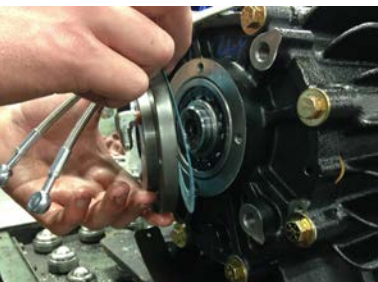

3. Remove the four (4) bolts that hold the rear bearing cover to the rear endplate and remove the rear bearing cover.



4. Remove the oil pump drive key from the end of the rotor.



5. **(Fan Cooled Only)** Remove the eleven (11) self-tapping screws that fasten the fan shroud "tin" to the pump. Remove the fan shroud support connecting the fan shroud "tin" to the rear endplate.



6. Remove the top two (2) bolts that hold the rear endplate to the pump housing and replace with two (2) 3/8-16 threaded dowels. Once in place, remove the lower six (6) 3/8 hex bolts.



7. Remove the rear endplate, gasket, and vanes.



8. Place a cushion beneath the rotor to prevent damage when the front endplate is unbolted (cardboard, rag, etc.).



9. **(Fan Cooled Only)** Remove the fan guard on the drive end side of the pump. Remove the fan and key from the rotor drive end by first loosening the fan hub screw. You may find it necessary to drive the hub apart with a screw driver in order to slide the fan assembly off of the rotor.



10. Repeat step 6 to drop the rear end of the rotor down onto the cushion.

**(Fan Cooled Only)** Remove the six (6) hex bolts holding the aluminum fan shroud to the front endplate and remove the shroud.



11. Gently guide the front endplate off of the (2) 3/8-16 threaded rod segments to fully settle the rotor body on the base of the housing bore.

**Remove the rotor with care from the housing. Place a Tag on the housing side that corresponds to your drive end side!**





12. Remove the four-way assembly, gaskets, and check valve assembly. Carefully turn the housing upside down so that the pump feet are facing the ceiling.

13. Inspect the housing for wear or damage. If the housing needs to be bored or honed, remove only as much material as is necessary to give a smooth clean bore.

The maximum overbore we recommend is 0.060 inches. A new housing has a bore of 7.875 inches.

If you bore or hone the housing, remove all connected accessories, including the fan shroud, 4-way valve, gaskets, etc.



14. Clean the housing of any debris and apply a liberal amount of lubrication to the housing bore.



15. (Optional) If there is damage evident to the bearings, they will need to be replaced. Once the rotor is removed, start by cutting off the old bearing inner race on both ends of the rotor. Be sure to line up the cutting wheel with one of the vane slots so as not to damage the rotor or seal sleeve.



16. Clean the rotor and rotor slots and inspect the rotor for wear or damage.

Place the clean rotor inside the housing with the drive end in the same orientation it originally was. This will be the side you tagged in step 11 of this procedure.



17. (Continuation of Step 15)  
Remove the two (2) inner races from the replacement bearings provided in your repair kit.

Place the inner races onto a hot plate and get them hot. Do not leave them on the plate so long that they become discolored.



Use a welding glove to take the hot inner race from the hot plate and slide it onto the rotor shaft.

The bearing race shoulder should be tight against the seal sleeve.

Install on both sides of the rotor.

Allow ample time for the inner races to cool and set onto the rotor before continuing.

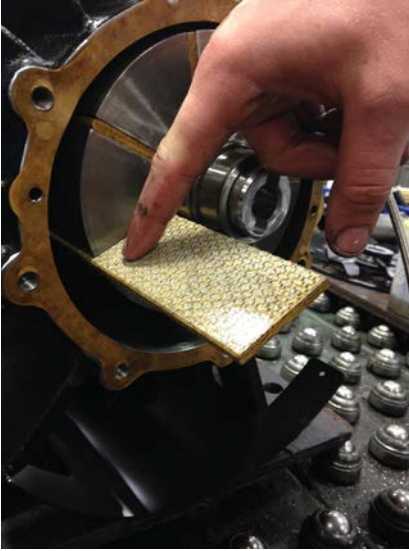

18. Inspect the original vanes for any delamination, chipping or other damage.

A new vane is flush with the outside diameter of the rotor.

If any of the vanes are worn more than 1/4", chipped or delaminated they should be replaced.

We highly recommend replacing vanes in sets. Apply a liberal amount of lubricant to the vanes before installing in the rotor slots.

It is always a good idea to have a spare set of replacement vanes on hand to reduce pump downtime.

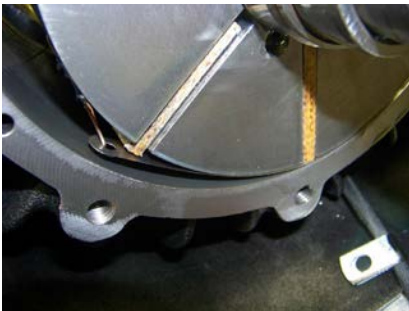

19. Shift the housing so that the intake (Square port) is hanging slightly off of the rebuild work surface.

Place one of the 0.007" shims between the rotor and rotor bore so that the shim is within the housing and will not interfere with the endplate when they are reinstalled.



Divert the pull wire into the housing cavity and out through the intake port.

Repeat for both ends of the rotor.



20. Remove the seals from the endplates. Inspect for damage, the seals should be soft and pliable.

Clean the endplate as needed. Apply new lubricant along the seal pilot in each of the endplates.

The seals need to be installed back to back. The faces without the oil groove should be touching.

We recommend using a seal driver tool to properly seat the seals in the endplate. Drive the seals into the endplate.

Repeat for both endplates.



21. Lubricate the roller bearing pilot in the endplate. Using a bearing driver, seat the roller bearing into the endplate.

Repeat for both endplates.



22. Install two (2) 3/8-16 threaded dowels so that they can support the weight of the endplate for installation.

Install one (1) new endplate gasket between the housing and the endplate, do not use any gasket sealer.

Carefully guide the endplate onto the rotor and threaded rod segments







23. Insert one (1) of the dowel pin “T-handles” into either of the dowel pin holes on the endplate through into the housing.

Snug the endplate close to the housing and install the 3/8 hex head bolts.

**(Liquid Cooled Only)** The 3/8 hex bolts located on the waterjacket side of the pump housing need to have high temperature (Red) RTV Silicone re-applied.



Tighten the endplate bolts to 35-40 ft-lbs of torque.

Repeat the process for the opposite endplate, but make sure to install the “T-handle” dowel pin on the same side of the housing as the other endplate, so as to prevent the rotor from twisting when the endplates are fully bolted into place



Rotate the housing right side up again, so the pump feet are on the work station.

24. Grasp the shim pull wires hanging out of the inlet, and gently pull to remove the 0.007” shims.

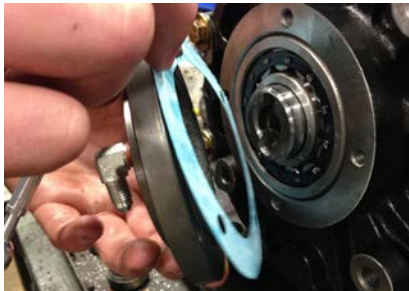

You may need to rotate your pump and pull the wires simultaneously to get them to release.

25. Reinstall the bearing cover gaskets, lubricate along the rotor bearing cover interface, reinstall the bearing covers (with wave washers installed)



26. Reinstall the oil pump drive key in the non-drive end of the rotor.

Use hardening gasket sealer on both sides of the oil pump gasket. Apply teflon tape to oil pump bolts.



Install oil pump to the rear bearing cover. Ensure the oil pump shaft is aligned with the drive key.

Reconnect the oil lines to the oil pump, and front bearing.

Do not overtighten fittings.



27. **(Fan Cooled Only)** Reinstall the fan assembly, the key should be pushed all the way to the end of the key slot on the drive end.

Make sure there is sufficient clearance to mount the fan cover when positioning the fan assembly. Tighten the fan hub screw.

Refer to step 9 for additional information.

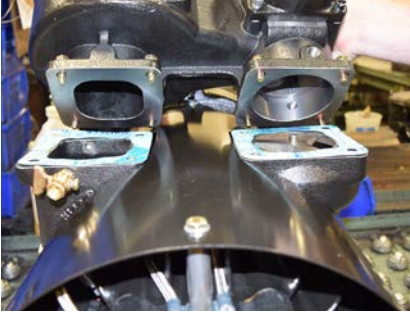

28. Install two (2) four-way gaskets to the housing interface.

Reinstall the four way manifold, making sure to line up the square port on the housing with the square port on the four way manifold.

Replace any gaskets / O-rings as needed.



29. We highly recommend pressure testing your pump for leaks before putting it to work. We test our pumps at 20 psi of pressure.

Put a 3" Male NPT plug in the exhaust port and a similar adapter that can connect to a controlled pressurized air supply in the inlet.

Spraying your pump with soapy water while pressurized will expose any bubbling air leaks in your vacuum pump.



30. Reconnect the pump to its oil reservoir and start at a slow R.P.M.

***The pump is now ready to go to work!***

# NVE

**National Vacuum Equipment, Inc.**

2707 Aero Park Drive  
Traverse City, MI 4968 USA

231.941.0215 Phone  
231.941.2354 Fax

800.253.5500 | [www.natvac.com](http://www.natvac.com)