

# Owner/Operator Manual

**For H-Series Pump Models: H1, H2 & H3**

**For HXL Series Pump Models: HXL2, HXL3 & HXL4**



**Warning!** This Manual includes important product safety information. Misuse of this product may result in severe injury or death. Read this manual carefully before attempting to use this product.

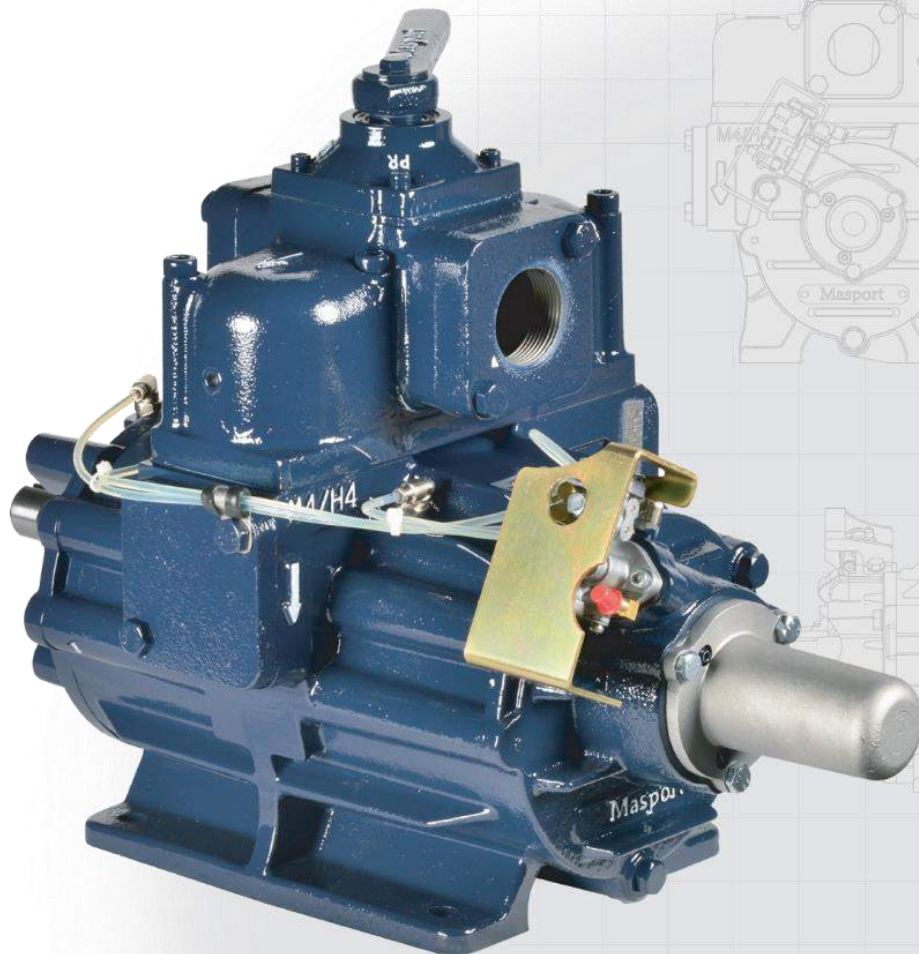

## Record of Purchase

**Serial Number:** \_\_\_\_\_

**Date Purchased:** \_\_\_\_\_

Please carefully read the installation, operation and maintenance instructions for your Masport vacuum pump. These are provided to assist you and they assume users have a basic level of mechanical competence.

If you have any questions about the correct installation, operation or maintenance procedures, please ask Masport.

## Masport Standard Limited Warranty

### Limited Warranty:

Subject to the Terms set forth herein and in the Masport Incorporated Standard Terms & Conditions of Sale, Masport Incorporated (“Masport”) hereby warrants to the Customer and the original end-user of the products (if such end-user is someone other than the Customer), as follows: The Masport products warranted hereunder will, in normal and intended use and service, be free from defects in material and workmanship during the Warranty Period described below.

### Warranty Period/Notice Requirements:

The Masport Standard Limited Warranty set forth above shall apply to covered defects that are discovered by the Customer and/or original end-user within twelve (12) months following the date set forth on the Masport invoice to Customer for the warranted product(s) (the “Warranty Period”). The Customer or original end-user must provide notice of covered defects in writing to Masport: 1) during the Warranty Period; and 2) within thirty (30) calendar days following their discovery (the “Notice Period”).

### Warranty Exceptions and Exclusions:

Notwithstanding anything herein to the contrary, the Masport Standard Limited Warranty set forth above does not cover any of the following, each of which are hereby expressly excluded therefrom:

- A. Defects that are not discovered during the Warranty Period;
- B. Defects that are not reported to Masport in writing within the Notice Period;
- C. Usual and customary deterioration or wear resulting from normal use, service, and exposure;
- D. Any products that are transported outside of the United States;
- E. Any shortages or discrepancies, all of which shall be exclusively governed by the Discrepancies, Shortages, Damages section of these Terms set forth above;

- F. Any claims for loss, damage, cost, or expense caused by any delay or damage in shipment or delivery damage, all of which shall be exclusively governed by the terms set forth in the Product Delivery section above;
- G. Shipping or other costs incurred to return the products to Masport for warranty inspection;
- H. Damage to persons or property other than the Masport products themselves, or for any incidental, consequential, or special damages.
- I. Any defect and/or any loss, damage, cost, or expense incurred by Customer, original end-user, or any third party to the extent the same arise out of, relate to or result, in whole or in part, from any one or more of the following:
  - a. Theft, vandalism, accident, war, insurrection, fire or other casualty;
  - b. Defects or damage caused by the Customer, original end-user, or any third party;
  - c. Exposure to corrosive, chemical, ash, smoke, fumes, or the like;
  - d. Any products that have been altered, modified, or repaired by Customer, original end-user, or any third party without Masport's prior written consent;
  - e. Any misuse of the products, including any use of the products not in conformity with product manuals or contrary to product warnings.

### **Resolution of Warranty Claims:**

In the event Masport is notified of a warranty claim in conformity with the notice requirements set forth above, Masport shall, with the full cooperation of Customer and/or original end-user (which shall include, without limitation, return of the product(s) for warranty inspection if requested by Masport), immediately undertake an investigation of such claim. To the extent Masport determines, in its reasonable discretion, that the warranty claim is covered by the foregoing Masport Standard Limited Warranty, Masport will, as Customer and original end-user's sole and exclusive remedy and at Masport's option, either:

- A. Ship replacement products to Customer or original end-user; or
- B. Ship repaired product(s) to Customer or original end-user.

Masport shall not be responsible to Customer or original end-user for the cost of dismantling any defective products or installing replacement products, all of which shall be and for all purposes remain the sole responsibility of Customer and original end-user.

### **Warranty Not Transferable Except to Original End-User:**

The Masport Standard Limited Warranty applies only to the Customer and the original end-user (if such end-user is someone other than the Customer). As such, this Warranty does not cover any Masport products that are sold or otherwise transferred to third parties (other than original end-user) or any subsequent purchasers of the products.

### **Customer's Responsibility to Masport Concerning Original End-Users:**

Customer warrants and represents that if it resells any Masport product or incorporates any Masport product into its own merchandise for the purpose of sale, Customer will:

- A. In all instances causes such purchaser to be bound by, and agree to, the Masport Standard Limited Warranty as set forth herein, including all terms and limitations thereof;
- B. Properly affix all warning labels to all Masport products;
- C. Provide the applicable Masport product manuals to such purchasers.

Customer shall indemnify, defend, and hold Masport harmless from any liabilities, losses, damages, or expenses (including reasonable attorney fees) to the extent the same are incurred by Masport in

connection with any claims, demands, suits, investigations, or other proceedings which are brought or asserted by any third party against Masport and that arise from the actions or inactions of Customer or its employees, agents, or subcontractors, including, without limitation, any failure by Customer to strictly comply with Customer's obligations to Masport concerning original end-users as set forth herein.

**Disclaimer of Implied Warranties:**

Customer has expressly acknowledged and agreed that: (i) the Limited Warranty set forth herein is an integral part of the Agreement pursuant to which the products were purchase; (ii) Customer (for itself and on behalf of the original end-user) has accepted said Limited Warranty as the sole and only warranty given by Masport to Customer and original end-user with respect to the products; and (iii) said Limited Warranty is reflected in the Purchase Price. Masport makes no other representations or warranties of any kind, whether express or implied, by operation of law or otherwise, with respect to any products, goods, or services sold or provided to the customer pursuant to this agreement, including without limitation any representation or warranty of merchantability or fitness for any particular purpose or use, all of which are expressly hereby disclaimed.

**Limitation on Liabilities and Damages:**

Except as is expressly set forth in this agreement or the Masport Standard Limited Warranty, Masport's liability under the agreement and under the standard limited warranty shall in no event exceed the actual cost of the products sold or provided to the customer under the applicable agreement. Further, Masport shall not, under any circumstances, be liable to the customer, the customer's customer, the original end-user, or any third party for any special, indirect, incidental, consequential, liquidated, or punitive damages.

**Governing Law/Jurisdiction:**

This Masport Standard Limited Warranty, shall be governed by, and construed in accordance with, the internal laws of the State of Nebraska, USA. Any legal action or proceeding arising under or with respect to this Masport Standard Limited Warranty, or the Masport products that are the subject matter of this Limited Warranty, shall be brought only in the district courts of Nebraska, or the United States District Court for the District of Nebraska, and, by Customer's placement of the subject product order, original end-user's agreement to and/or acceptance of the Masport Standard Limited Warranty, and acknowledgment of Customer's order by Masport, Customer, original end-user, and Masport each hereby accepts for itself and in respect of its property, generally and unconditionally, the jurisdiction of the aforesaid courts and hereby irrevocably waive any objection thereto, including, without limitation, personal jurisdiction or *forum non conveniens*.

## Contents

<b>Introduction</b> .....	5
<b>Intended Use</b> .....	6
<b>Installation</b> .....	6
<b>Plumbing</b> .....	6
<b>Recommended System Components</b> .....	8
<b>Component Checklist</b> .....	10
<b>Drive Systems</b> .....	10
<b>Rotation of the Pump</b> .....	10
<b>Pump Speeds and Power Requirements</b> .....	11
<b>Vacuum Relief Valve</b> .....	12
<b>Pressure Relief Valve</b> .....	12
<b>Pump Lubrication</b> .....	13
<b>Flushing Information</b> .....	15
<b>Maintenance and Important Operating Tips</b> .....	16
<b>Troubleshooting</b> .....	18
<b>Pump Service</b> .....	19
<b>Exploded Views</b> .....	33

## Introduction

Congratulations on your purchase of a Masport Pump. We are delighted you have chosen to join the community of satisfied customers using Masport equipment in daily professional operations.

Our products are backed by over 100 years of engineering excellence and are specifically designed and engineered to meet the needs of hard working pumpers around the world.

Our expert product development, manufacturing and distribution teams work to rigorous quality standards and a strict testing regime. To produce our precision pumps, we only use the finest quality components and materials to ensure the durability of your vacuum pump. Every pump is factory tested before shipping and is backed up with a one year warranty against all manufacturing defects. This system ensures you receive a quality product.

This manual provides all the information you will need to run your pump correctly to ensure a long and efficient service life. If you have any questions, please contact your local Masport representative or Masport directly.

### **Our History:**

Masport designs, manufactures, and assembles vacuum pumps and associated products. The company was established by Harold Mason and Reuben Porter under the name City Engineering in Auckland, New Zealand, in 1910. Within a couple of years, the Mason and Porter business, or Masport as the company later became known, was manufacturing vacuum pumps and a range of engines to power all types of farm equipment.

Masport first looked to international markets with trial exports of vacuum pumps to the United States in 1956 – and has never looked back since. In 1991 the ownership of Masport’s vacuum pump division was transferred to Skellerup Holdings – an iconic New Zealand Company which also celebrated its centenary in 2010.

With Masport on board you have an efficient and reliable pump backed by the best service and support that has made Masport the #1 choice for pumpers worldwide.

### **Over 100 Years of Engineering Excellence**



## Intended Use

Masport Vacuum/Pressure Pumps are intended to be used for loading and unloading of liquid material. These pumps are commonly used for liquid waste transport, septic tank cleaning, oil field water trucks, car wash or grease trap cleaning and many other industrial applications.

---



**Warning!** Masport pumps must not be used to move flammable or highly caustic material. Use of this pump for moving hazardous material may result in machinery failure, bodily injury or even death.

---

## Installation

Whatever the configuration of the vacuum system on your truck or trailer, all components and plumbing must be of adequate size or the system will not operate correctly.

All models (except for the H1F) require a minimum of 1 ½" I.D. diameter plumbing and corresponding 1 ½" I.D. Masport components. The H1F can be plumbed with 1" I.D. connections.

---



**Warning!** Do not use a hose smaller than 1 ½" I.D. or the airflow will be restricted and the pump may overheat and be damaged.

---

Ensure all pipes, hoses and fittings are thoroughly cleaned before assembly and free of any kind of dirt or debris. Any solid particles ingested by the pump may cause irreparable damage that will result in loss of performance and increased operating noise. Some form of pipe sealant should be used on all thread connections to prevent leaks.

## Plumbing

### Four-Way Valve:

For pumps fitted with a valve, the four-way valve is used to change the pump operation from vacuum to pressure or pressure to vacuum by rotating the handle through 90 degrees. The center position is neutral.

Either valve port can be plumbed to the inlet or the exhaust using 1 ½" pipe.

The valve handle is mounted on a four-sided shaft. It can be repositioned through four different positions to suit the operator's needs and access requirements.

## Indicator Washer:

All pumps that are fitted with a valve are supplied with an Indicator Washer. The Indicator washer secures the valve handle and shows the direction to turn the handle for pressure or vacuum operation. The Indicator Washer is reversible allowing the washer to be orientated to your specific setup and plumbing configuration.

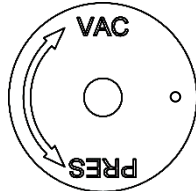

Indicator Washer Side One



Indicator Washer Side Two



**Warning!** The installation of the Handle Indicator Washer is the responsibility of the installer. Incorrect orientation of the Handle Indicator Washer may result in unexpected vacuum or pressure that may result in machinery failure, bodily injury or even death.

---

## Hose:

Any hose used in the system is to be rated for at least 28”Hg vacuum and 25 PSI pressure, and withstand air/oil temperatures up to 300 F. Hot-tar and asphalt hose is designed for use in this of environment.



## Recommended System Components

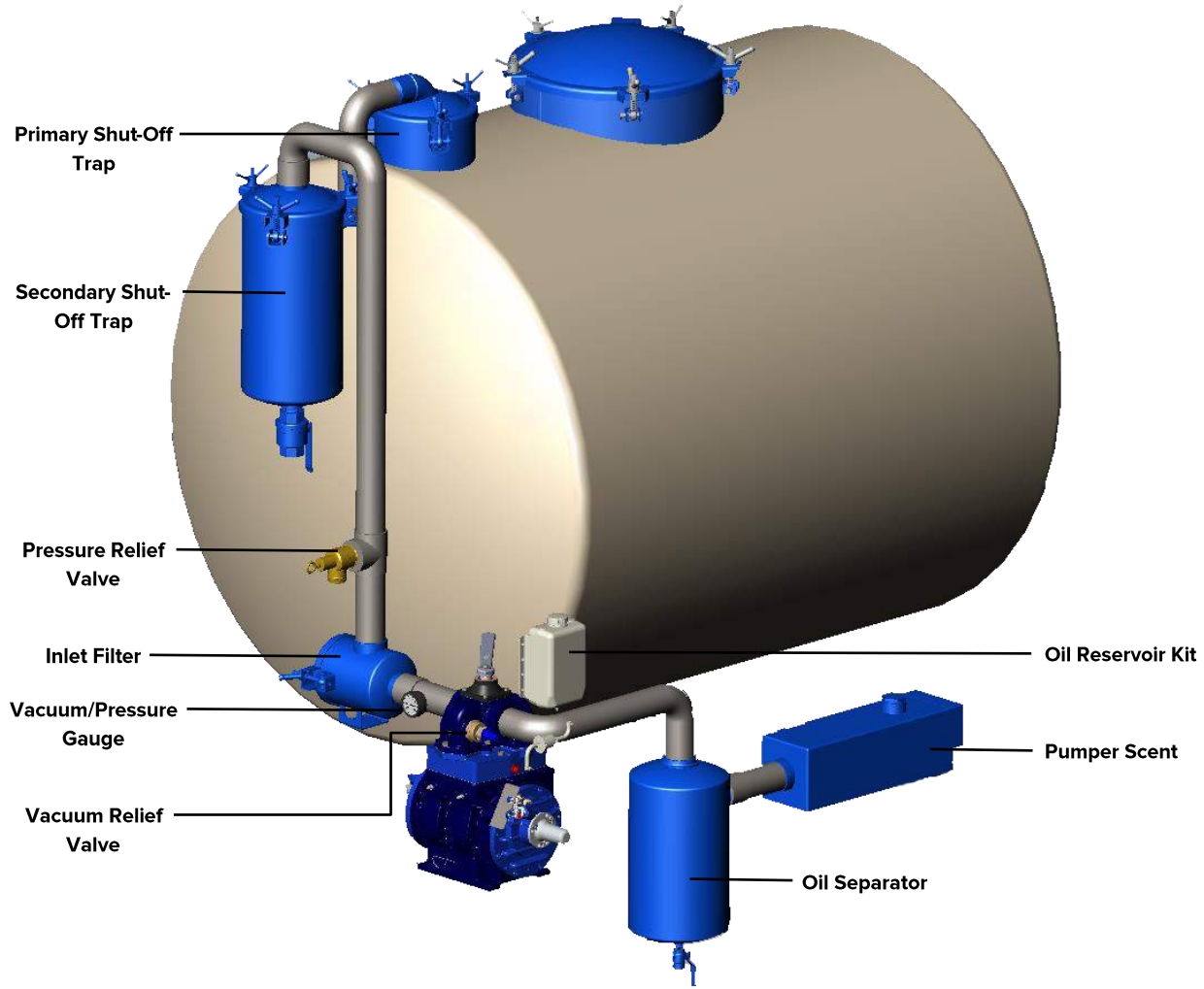

### **Primary Shut-Off Trap:**

A float ball shut-off that prevents liquid in the tank from overflowing into the system and entering the pump. Liquid entering the pump can damage or destroy the pump.

### **Secondary Moisture Trap (Scrubber):**

Removes liquid still in the air steam after passing through the Primary Trap. The Scrubber should be drained after every load.

### **Inlet Filter:**

Prevents small particulate matter from entering the pump. This filter should be checked and cleaned, or replaced regularly.

## **Vacuum/Pressure Gauge:**

Required to properly monitor the performance of the system. It should be located between the Scrubber and the (the clean side) Pump to prevent gauge failure due to foreign material.

## **Vacuum Relief Valve:**

Governs the operating vacuum level. It should be installed at the pump so that if a liquid level trap is activated or a hose collapses the pump is prevented from overheating.

## **Pressure Relief Valve:**

Regulates the amount of pressure the system is exposed to. It should be located between the Scrubber and the Pump on the clean side of the system.



**Warning!** Operating your system without properly installed vacuum and pressure relief valves in good working order could lead to equipment damage or catastrophic failure resulting in severe injury.

---

## **Oil Separator (Muffler):**

Removes oil from the pump exhaust. It is equipped with a ball valve at the bottom and should be drained at least twice daily.

## **Oil Reservoir Kit:**

The oil reservoir kit supplies filtered lubricating oil to the pump.

## **Flushing Kit:**

The flushing kit supplies a cleaning fluid to the pump. This extends pumps life by preventing the build-up of carry-over from liquid level traps causing contamination.

## **Pumper Scent (Optional):**

The Pumper Scent box removes odor from the exhaust. Its use is recommended in environmentally sensitive areas.

## **Swing Check Valve (Flange Model Only):**

A swing check valve should be installed somewhere in the system to prevent the pump from spinning backwards when the pump is disengaged with vacuum or pressure in the tank. If the pump is allowed to spin backwards, then there is air flowing backwards through the system which could carry foreign material into the pump and cause severe damage. The swing check valve must be installed in a horizontal position.

## **Remote Four-Way Valve (Flange Model Only):**

A remote four-way valve must be used if both vacuum loading and pressure off-loading is desired. With one side of the valve attached to the intake side of the pump and the other attached to the

exhaust side of the pump, the mode of operation can be changed from vacuum to pressure by simply turning the selector lever.

## Component Checklist

Below is a checklist of the components required to complete a Vacuum Only or Vacuum/Pressure system.

Part Number	Description	Vacuum	Vacuum/Pressure
16311	Primary Shut-Off Trap 1 ½”	X	X
16410	Secondary Moisture Trap (Scrubber) 1 ½”	X	X
15115	Inlet Filter 1 ½”	X	X
21053	Vacuum/Pressure Gauge	X	X
569023	Vacuum Relief Valve	X	X
25038	Adjustable Pressure Relief Valve		X
15477	Aluminum Oil Separator 1 ½”	X	X
13023	Oil Reservoir Kit	X	X
13027	Flushing Kit	X	X
15612	Pumper Scent Chamber 1 ½”	X	X
25158	Swing Check Valve	X	

## Drive Systems

Whichever drive system is chosen (PTO, Hydraulic, Engine Drive or Pulley and Belts), ensure it is adequately sized to suit the pump requirements. The chosen motor needs to satisfy the horsepower and RPM requirements of the pump.

Alignment is important. If the vacuum pump is not aligned properly, it will cause excessive wear on the drive element and pump bearings.



**Warning!** Ensure that all moving parts are properly guarded.

## Rotation of the Pump

The pump can be driven from either of the two shafts to accommodate a clockwise or a counter-clockwise drive system. There is an arrow cast into the pump housing and/or the valve housing indicating proper pump rotation. Ensure that the drive system direction corresponds to the direction shown on the pump.

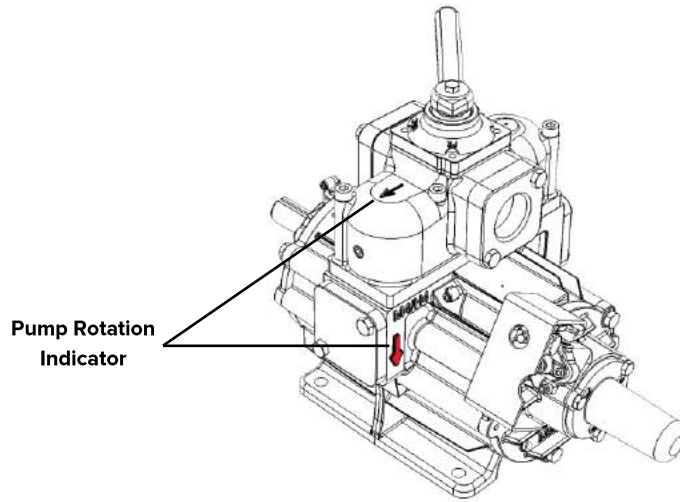

**Warning!** Always run the pump in the direction indicated.

## Pump Speeds and Power Requirements

The table below provides the recommended speed and power requirements for each pump model for optimal pump life and performance.

Pump	RPM	Vacuum (" Hg)					Pressure (PSIG)		
		5	10	15	20	27	5	10	15
H1F	1,250	0.8 hp	0.8 hp	0.9 hp	1.0 hp	1.2 hp	0.9 hp	1.3 hp	1.6 hp
	1,425	0.9 hp	1.0 hp	1.0 hp	1.2 hp	1.4 hp	1.0 hp	1.5 hp	1.8 hp
	1,750	1.1 hp	1.2 hp	1.3 hp	1.5 hp	1.8 hp	1.2 hp	1.9 hp	2.2 hp
H2F	1,250	1.8 hp	2.1 hp	2.2 hp	2.4 hp	2.7 hp	2.9 hp	3.1 hp	3.9 hp
	1,425	2.1 hp	2.4 hp	2.5 hp	2.8 hp	3.1 hp	3.2 hp	3.4 hp	4.3 hp
	1,750	2.6 hp	3.0 hp	3.2 hp	3.5 hp	3.6 hp	4.0 hp	4.3 hp	5.4 hp
H3F	1,250	2.4 hp	2.8 hp	3.0 hp	3.4 hp	3.9 hp	3.5 hp	5.0 hp	6.3 hp
	1,425	2.8 hp	3.3 hp	3.5 hp	3.9 hp	4.5 hp	4.0 hp	5.8 hp	7.3 hp
	1,750	4.0 hp	4.7 hp	5.0 hp	5.7 hp	6.5 hp	5.0 hp	7.1 hp	9.0 hp
HXL2	1,250	1.8 hp	2.1 hp	2.2 hp	2.4 hp	2.7 hp	2.9 hp	3.1 hp	3.9 hp
	1,425	2.1 hp	2.4 hp	2.5 hp	2.8 hp	3.1 hp	3.2 hp	3.4 hp	4.3 hp
	1,750	2.6 hp	3.0 hp	3.2 hp	3.5 hp	3.6 hp	4.0 hp	4.3 hp	5.4 hp
HXL3	1,250	2.4 hp	2.8 hp	3.0 hp	3.4 hp	3.9 hp	3.5 hp	5.0 hp	6.3 hp
	1,425	2.8 hp	3.3 hp	3.5 hp	3.9 hp	4.5 hp	4.0 hp	5.8 hp	7.3 hp
	1,750	4.0 hp	4.7 hp	5.0 hp	5.7 hp	6.5 hp	5.0 hp	7.1 hp	9.0 hp
HXL4	1,100	4.4 hp	4.7 hp	4.9 hp	5.4 hp	5.9 hp	4.9 hp	6.9 hp	8.7 hp
	1,250	4.9 hp	5.2 hp	5.5 hp	6.0 hp	6.6 hp	5.5 hp	7.7 hp	9.7 hp
	1,400	5.6 hp	5.9 hp	6.3 hp	6.9 hp	7.5 hp	6.3 hp	8.8 hp	11.0 hp



**Note:** Heat build-up is the limiting factor in the pumps performance. Operating above or below the recommended speed range will increase the heat produced and negatively impact the life of the pump.

## Vacuum Relief Valve

The vacuum relief valve should be set at a maximum continuous working vacuum level of 20" Hg at sea level for optimum pump life and performance.

The working vacuum level should be decreased by 1" Hg for every 1,000ft of elevation.

To set the vacuum relief valve:

- ▶ Unscrew and remove the Blue Dust Cap;
- ▶ Loosen the Lock Nut and adjust the vacuum level by increasing or decreasing spring tension with the Adjusting Nut; and
- ▶ When the vacuum level is set retighten the Lock Nut and screw the Blue Dust Cap back on.

The vacuum relief valve setting should be verified by using a quality liquid filled vacuum gauge.

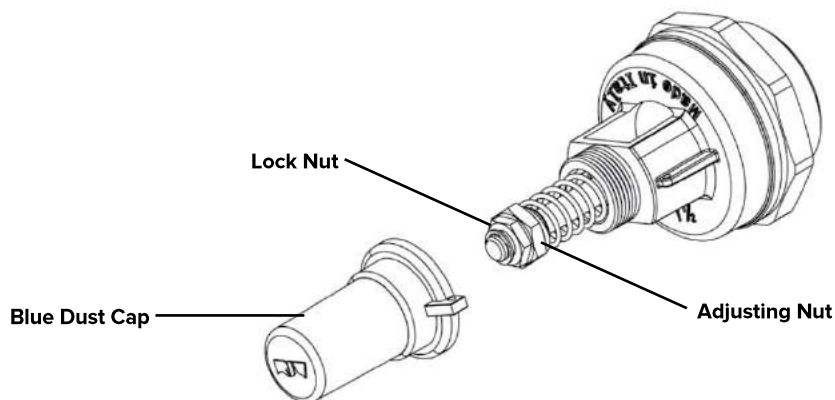

**Warning!** The vacuum relief valve is not set at the factory.

## Pressure Relief Valve

It is recommended to set the pressure relief valve below 15 PSI. This level is adequate in majority of applications.

For pressure settings above 15 PSI the tank manufacturer should be consulted for recommended operating pressures.

To set the pressure relief valve consult the manufacturers setup guide.

## Pump Lubrication

Rotary Vane Vacuum Pumps require a high quality non-detergent Rotary Compressor Oil or Rotary Turbine Oil. Oil specifically formulated for Masport pumps is available from your local Masport representative or by contacting Masport Inc.

### 1 Gallon Bottles

- ▶ Part # 13996 – Summer Blend
- ▶ Part # 13998 – Winter Blend

### 6 Gallon Case

- ▶ Part # 13997 – Summer Blend
- ▶ Part # 13999 – Winter Blend



**Warning!** Do not use transmission fluid, automotive motor oil, power steering fluid, used oil, vegetable oil, brake fluid, hydraulic fluid, gear oil or scented oil in a Masport pump.

Substitute oils approved for temporary use in Masport pumps:

- ▶ Shell Turbo T Oil 32, 68, 100  
Shell Oil Company – Houston, TX 800-231-6950
- ▶ Monolec Compressor Oil\*  
Lubrication Engineers – Fort Worth, TX 817-834-6321
- ▶ Mobil SHC 525 (Synthesized Hydrocarbon)  
Mobil Oil Company – Fairfax, VA 800-662-4525
- ▶ Anderol 497  
Anderol Inc – East Hanover, NJ 888-263-3765
- ▶ Chevron GST 32, 68  
ChevronTexaco Corporation – San Ramon, CA 800-822-5823
- ▶ Regal Oil R & O 32, 68  
ChevronTexaco Corporation – San Ramon, CA 800-822-5823

\* Monolec Compressor Oil is colored red and should not be confused with transmission fluid.

Use of these oils will extend the life of the pump and ensure proper performance and lubrication.



**Note:** Oils numbered 32 & 46 are for winter use. Check pour point to determine minimum temperature. Oils numbered 68 & 100 are for summer use.

## HXL Series:

All Masport HXL Series pumps are equipped with an automatic oil pump. This system is pre-set to deliver the required amount of lubricating oil to the vacuum pump. The oil pump is maintenance free and requires no operator adjustment.

**Oil Reservoir Mounting:**

The oil pump must be connected to an oil reservoir tank. The oil reservoir tank must be mounted higher than the oil feed connection on the oil pump so that the oil will be fed by gravity.

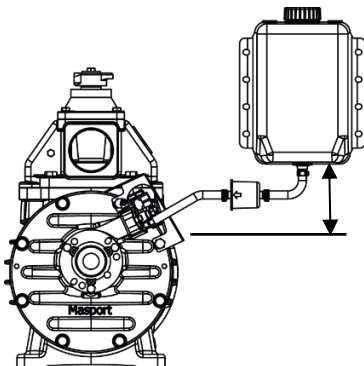
**Prior to Start-Up:**

Before running the pump for the first time (and any time after pump teardown or if it has been out of service for some time) follow the below procedure:

- ▶ To bleed the oil pump loosen but do not remove the bleed screw on the oil pump.
- ▶ Ensure there is adequate pump oil in the oil reservoir and bleed the oil feed line from the oil reservoir to the oil pump.
- ▶ When oil starts to drip from the bleed screw on the oil pump, retighten it.
- ▶ Pour 1 - 2 oz. of pump oil into the vacuum pump inlet and rotate the pump by hand several times to coat the cylinder with a fresh film of oil.
- ▶ After start-up, observe the transparent oil lines coming from the oil pump to confirm that oil is flowing from the oil pump to the cylinder ports.

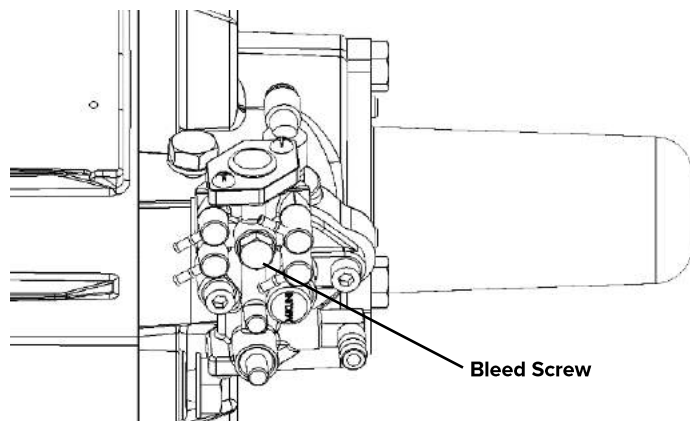
**H Series:**

All Masport H Series pumps require an adjustable pressure/vacuum actuated system. This system utilizes two adjustable oil sight feed valves that can be mounted directly at the bearing (for flange vacuum only models) or remote mounted (integral pressure/vacuum valve models).

When the pump is operating in vacuum mode, lubricating oil is drawn into the sight feed valves by the vacuum produced by the pump. Under vacuum, the line to the exhaust side of the pump acts as a vent line. When operating in pressure mode, the line from the pumps exhaust port pressurizes the oil tank, forcing oil into the sight feed valves to lubricate the pump. As this is actuated by system pressure, once the sight feed system is set, it will tend to compensate and self-regulate for any changes.

The rate of oil supply to the pump can be checked by observing the drops falling inside each Dripper through the sight glass. This should only be finalized when the vacuum is up to full operating level and the pump has fully warmed up (i.e. after approximately 30 minutes of running.) The flow rate should be adjusted to no less than the recommended drop rate shown below:

Driving HP	1.3	2.0	2.7	3.4	4.0	5.4	6.7	8.7	10.1
Drops per Min	5	7	9	11	12	16	20	26	30

To enhance protection against contamination damage it is recommended to have the oil flows exceed the minimum rate.

The oil flow rate can be adjusted by turning the adjusting screw clockwise to reduce, counter-clockwise to increase. Ensure the locking gland nuts are tight to avoid Dripper adjustment while the pump is operational.

## Flushing Information

Masport vacuum pumps require little regular maintenance except for flushing the pump weekly or anytime liquid or solids have been allowed to enter the pump.

Masport vacuum pumps are best flushed by using a Masport Flushing Kit and specially formulated Flushing Fluid. These are available from your local Masport representative or by contacting Masport.

### Plastic Flushing Kit

- ▶ Part # 13027

### 1 Gallon Flushing Fluid Bottle

- ▶ Part # 13989

### Steel Flushing Kit

- ▶ Part # 13030

### 6 Gallon Case of Flushing Fluid Bottles

- ▶ Part # 13990



## Flushing Procedure:

Flushing frequency: weekly, preferably at the end of a workday, more often if carry-over from traps contaminate the pump.

- ▶ Connect the Flushing Kit to the flushing port on the Masport vacuum pump

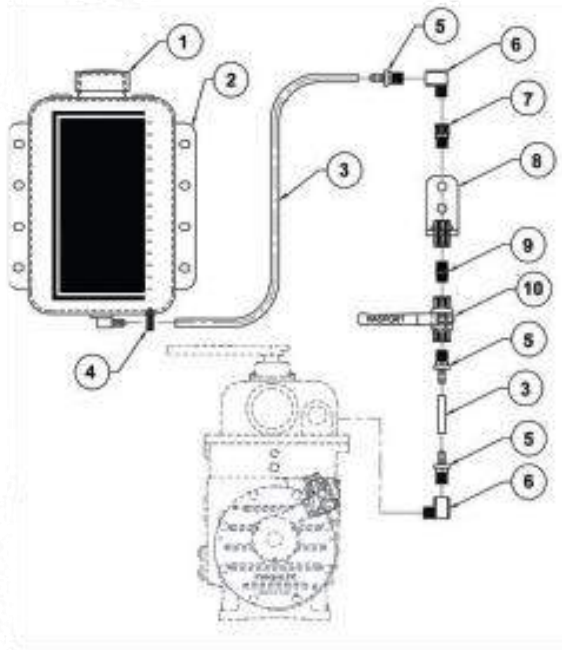

- ▶ Start the vacuum pump and bring vacuum to 15”Hg.
- ▶ Open the ball valve to begin flushing fluid flow.
- ▶ Continue to run the pump until the fluid level drops 1 graduation (approximately 7 fluid ounces).
- ▶ Close the ball valve.
- ▶ Continue to operate the pump for 3 additional minutes to ensure all fluid is purged from the pump.
- ▶ Stop the vacuum pump.
- ▶ Drain the oil separator and dispose of used fluid at an approved recycling site.

## Maintenance and Important Operating Tips

To keep the pump in a workable condition operators should undertake regular maintenance and keep a written log of those checks.

### Before Starting:

- ▶ Ensure a vacuum relief valve and a pressure relief valve are installed in the system and adjusted to recommended settings, taking into account the altitude of the job location.
- ▶ Always bleed the tank to atmospheric pressure before switching the valve from vacuum to pressure or from pressure to vacuum.

## Every Load:

- ▶ Drain the scrubber after each tank load. If nothing drains when the ball valve is opened never assume it is empty, check for a blockage in the valve.
- ▶ Check the oil level in the oil reservoir, and fill as required.
- ▶ Monitor vacuum/pressure and temperature gauges to detect any irregularities or problems.

## Daily:

- ▶ Add oil approximately every 10 hours of operation or when the oil reservoir shows the level is low. Only use approved lubricants.
- ▶ Drain the oil separator twice daily or every time switching the Vacuum Pump from vacuum to pressure mode. A brass ball valve is mounted at the bottom for easy draining.

## Weekly:

- ▶ Flush the pump weekly with Masport Flushing Fluid, or anytime liquids or solids have been allowed to enter the pump.
- ▶ Check and clean the Inlet Filter. Ensure the filter is completely dry before refitting. This checking process must be done anytime contamination may have entered the system.
- ▶ Check to ensure the pump RPM is within the recommended range. Running the pump too fast or too slow may cause damage.
- ▶ Wash any dirt off the pump as it needs to be clean to allow heat to radiate and prevent it from overheating.

## Annually:

- ▶ Check bolt mountings, drive coupling alignment and condition, and vane wear.

## Storage:

- ▶ If the pump is to be sitting for an extended period of time it needs to be flushed prior to storage. After flushing, pour oil into all bearing lubrication ports to protect the bearing surfaces and oil injection points on the pump to eliminate rust formation on the rotor and cylinder.
- ▶ Rotate by hand monthly to distribute oil.

## For Safe Operation:

- ▶ Never use the pump to move flammable or highly caustic material.
- ▶ Do not open any ball valve on any components when the tank is under vacuum, as this will cause foreign material to enter the pump.
- ▶ Do not over speed or under speed the pump as either will cause overheating.
- ▶ Do not engage power take off at high RPM. Only engage at idle.
- ▶ Always disengage the pump when driving to or between job sites.
- ▶ Do not reuse the oil drained from the oil separator. Take it to an appropriate recycling site.
- ▶ Never run the pump without oil.

- ▶ Never spin the pump backwards.
- ▶ Never remove the stub shafts from the rotor. The rotor has been machined as a complete unit for exact balance. Removing the stub shafts will destroy the factory-set clearances and balance.
- ▶ No maintenance should be undertaken, or parts be removed if there is either pressure or vacuum in the tank.

## Troubleshooting

### The Pump Overheats

#### Potential causes to check and resolve:

- ▶ Inadequate level of oil, or no oil in the pump.
- ▶ RPM in excess of recommended levels.
- ▶ Continued operation above recommended maximum vacuum and pressure levels.
- ▶ Blocked Inlet Filter.
- ▶ Pump is covered in mud and/or dirt.
- ▶ Plumbing diameter is of an insufficient size.
- ▶ Blockage in exhaust.

### The Rotor does not Rotate

#### Potential causes to check and resolve:

- ▶ Damaged vane(s).
- ▶ Damaged bearing(s).
- ▶ Issue with the drive system.
- ▶ Ice frozen inside the pump.

### The Pumps Performance is Impaired

#### Potential causes to check and resolve:

- ▶ Four-way valve is in the neutral position.
- ▶ Worn vanes.
- ▶ Worn shaft seals.
- ▶ Leaks in the tank or pipework.
- ▶ Plumbing diameter is of an insufficient size.
- ▶ Non-return valve is blocked and does not open fully.
- ▶ Blocked Inlet Filter.
- ▶ RPM rate below recommended level.
- ▶ Collapsed hose in the system setup.

- ▶ Blockage in exhaust.

For further issues or additional information contact an authorized Masport distributor or Masport directly.

## Pump Service

The following repair techniques are given for use on pumps that do not have damage to the cylinder or end covers to the extent that they need to be re-machined. These procedures are intended for use when the vanes and bearings of the pump require replacement. They should not be considered as total rebuild instructions.



**Note:** Any service or repair work on your pump should be performed by a qualified mechanic with the proper tools and experience working with vacuum pumps.

Installations requiring re-machining of the pump components should be done by an authorized Masport repair facility. For the nearest authorized rebuild center, contact Masport directly.

### Replacement Parts Kit:

The Replacement Parts Kits contains all the necessary components to rebuild or service your pump. All Replacement Parts Kits contain the following items:

- ▶ Vane Pack
- ▶ Bearings
- ▶ Bearing Spacers
- ▶ Oil Seals
- ▶ End Cover Shims
- ▶ End Cover O-Rings (where fitted)
- ▶ Valve Gaskets
- ▶ Flange Gaskets

The Replacement Parts Kit to use on each model are as follows:

Pump	Rebuild Kit Part Number	Serial Number
H1	14613	All
H2	14637	All
H3	14638	All
HXL2	14617	Less than Q06128
HXL2	14637	Q06128 and greater
HXL3	14618	Less than Q07076
HXL3	14638	Q07076 and greater
HXL4	14619	All

## Disassembly:

The following instructions are written, assuming that the pump being serviced has been removed from the base it was mounted on. It is possible to carry out installation of the parts kit with the pump mounted, but for best results it is recommended that it is removed from the stand.

---



**Warning!** Disconnect the pump drive to ensure the pump cannot be accidentally started during service and to allow the shaft to be rotated by hand.

---

## End Cover Removal:

Before removing the cylinder end cover, clean the outside of the pump to prevent dirt and debris from getting into the cylinder.

Mark the drive side end cover and the corresponding end of the cylinder and rotor shaft, using a center punch. Marking these will avoid the possibility of assembling the pump with the end covers on the wrong ends.

Remove the shaft guard and support the end of the shaft so that the rotor will not drop when the end cover is pulled from the bearing. A notched piece of wood can be used to support it from below, or a long nipple can be screwed into the valve above the shaft and a strap can be hung from the nipple to support the shaft.

For HXL Series pumps, if working from the oil pump end of the cylinder, start by removing the oil pump guard. The guard bolts are longer than the other end cover bolts so their location should be noted. Disconnect the oil line to the fitting in the end cover and remove the oil pump. The oil pump mounting screws are different lengths, so note their locations as they are being removed. Remove the oil pump drive assembly.

Remove the bolts around the perimeter of the end cover.

In order to maintain factory set clearances avoid damaging the dowel pins during end cover removal. To properly remove the end cover, work evenly from each side of the cover, which will help to avoid misalignment of the end cover and bending of the dowel pins. Ensure that the rotor does not slide out with the end cover. As necessary use a rubber mallet to drive the rotor shaft back towards the end cover that is still bolted on to free the end cover from the bearing.

When the end cover is far enough away from the cylinder install a second shaft support behind the end cover and release the first. Slide the end cover completely off the rotor shaft.

---



**Warning!** Under no circumstances should the end cover be pried or hammered off of the cylinder as this will potentially result in damage to the sealing surfaces.

---

The end clearance is adjusted by means of color coded Shim Gaskets between the end cover and the cylinder. Make note of the color and quantity of any Shim Gaskets when removing the end cover. The matching quantity and color will need to be used on reassembly.

The marker holes on the Shim Gaskets identify the thickness – i.e. two holes indicates a thickness of 0.002” and three holes indicates a thickness of 0.003”

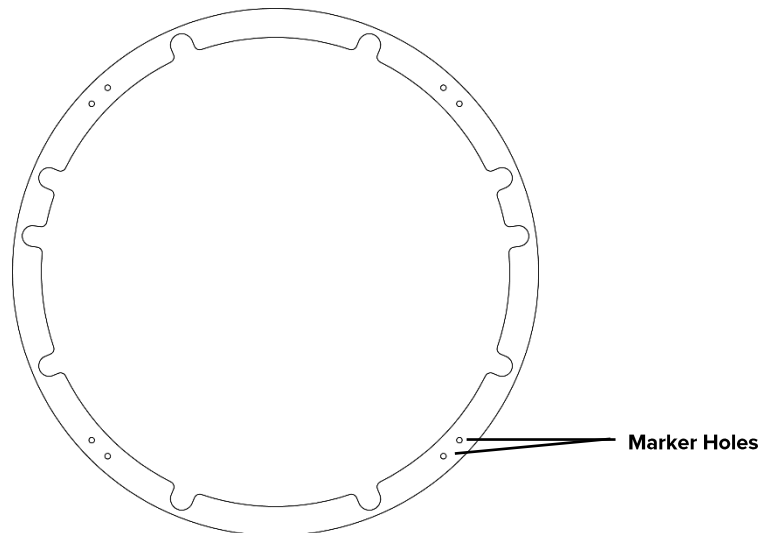

**Note:** If simply replacing the vanes only please skip to the Vane Wear Check section in Parts Inspection, Cleaning and Replacement.

---

### **Rotor Removal:**

With the one end cover removed, the rotor can be pulled out of the cylinder. The bearings are a slip fit in the end covers, but due to the tight clearance, the bearing may bind in the end cover if it is not pulled out straight. If it does not pull free on the first try, put it all the way back in, using a rubber mallet, and start over again. Putting it all the way back in will realign the bearing with the housing and allow it to pull free from the cover.

Once the rotor has been removed, the remaining end cover can be removed, as required, by following the same procedure detailed above in the End Cover Removal section.

### **Parts Inspection, Cleaning and Replacement:**

#### **Vane Wear Check:**

The pump should be inspected for vane wear at least once a year. If vane wear is not monitored, the vanes can become too short causing excessive rotor and cylinder wear and eventually result in vane breakage.

Measure the vanes to see if they are within the usable limit. If they are not they should be discarded and replaced. The vanes should be replaced when their height is below the usable limit detailed in the table below:

Pump	Vane Usable Height ("
H1	> 1 3/8"
H2	> 1 5/8"
H3	> 1 5/8"
HXL2	> 1 5/8"
HXL3	> 1 5/8"
HXL4	> 2 1/4"

Inspect the sides of the vanes to see if they are bent, out of parallel, worn to a concave shape on one side or have frayed edges. Any of these conditions require part replacement. These characteristics could indicate foreign material caught alongside the vane, a burr in the edge of the rotor slot or improper lubrication. Each of these possible causes should be investigated and corrected before the pump is reassembled.

Inspect the edge of the vane that contacts the cylinder for frayed edges. If detected this requires part replacement. Frayed edges can indicate improper lubrication or that the pump has been operated for extended periods of time beyond its rated limits. Each of these possible causes should be investigated and corrected before the pump is reassembled.



**Note:** If simply replacing the vanes only please skip to the Installing the Vanes section in Reassembly.

---

### Cylinder Inspection:

With the end cover removed inspect the cylinder for damage or corrugation. Prior to inspection, the cylinder should be cleaned inside and out to allow a more thorough inspection.

Inspect the interior of the cylinder for cracks and deep gouges around the circumference and corrugation across the length of the bore. Cracks in the housing will require part replacement.

The detection of corrugation or gouges across the length of the cylinder can indicate inadequate horsepower transfer, operation below minimum recommended speeds, foreign material sticking the vanes in their slots, or operation beyond recommended vacuum limits. Each of these possible causes should be investigated and corrected before the pump is reassembled.



**Note:** If cylinder scoring is deeper than .005" or if corrugation can be felt the cylinder should be bored, honed and the seal gap reset.

---

## **Bearing and Spacer Inspection:**

It is difficult to visually determine the condition of a bearing. If there is obvious damage such as discoloration (bluing) of the bearing or the race, there is definite damage and the bearing and spacer should be replaced. If there is no discoloration and minimal amounts of carbon or oil sludge build-up on the bearing cage, it can probably be cleaned in solvent, blown out with an air hose, oiled and reused.



**Note:** There is no guarantee that the bearings are not damaged and with the pump disassembled to this point, it is advisable to replace them.

---

The outer circumference of the spacer should be inspected for signs of contact with the bore of the end cover bearing housing. If there has been contact, it could be a sign that the bearing is worn and needs to be replaced.

## **Bearing and Spacer Removal:**

Before removing the bearing and spacer any burrs on the shaft should be removed with a flat file.

For HXL Series pumps, loosen the set screw in the worm gear for the oil pump drive and remove the worm gear from the shaft.

Once the shaft is free of burrs, the bearing and spacer can be pulled by means of a bearing puller. Bearings should be removed only using the proper tools. A bearing puller is the only tool that will give satisfactory results. Prying or hammering will only risk damage to the components.



**Note:** The spacers are not reusable and must be replaced when removed.

---

Do not install new bearings and Spacers at this time. Follow the Rotor Inspection and Cleaning instructions first.

## **Rotor Inspection and Cleaning:**

Inspect the rotor carefully for any cracks - especially if disassembly was due to pump seizure. Any cracks in the rotor will require replacement of the part.

With the bearings and spacers removed, lightly file with a flat file along all edges of the vane slots to remove any burrs or nicks that may have occurred from either contact or from foreign material.

Once all the burrs are removed, the ends and diameter of the rotor should be gone over lightly with 400 grit wet/dry sandpaper to remove any carbon or varnish deposits left by the oil.

## **Bearing and Spacer Replacement:**

Place the new spacer on the shaft. Ensure that the spacer is installed on the rotor shaft with the larger bore diameter facing towards the rotor.





**Note:** Incorrect installation of the spacer will cause bearing failure and damage to the pump.

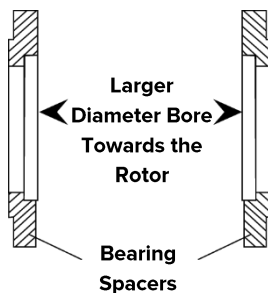

The new bearings and spacers can be pressed onto the shaft using a bearing press. When pressing them on ensure the pressure is only applied to the bearing inner race. If a bearing press is unavailable a length of pipe can be used to drive the bearing onto the shaft. If this method is used ensure that the pipe diameter is equal to the bearing inner race, and any dirt or pipe scale is removed before use to prevent contamination.

### **End Cover Inspection and Cleaning:**

Each of the end covers should be inspected for surface damage from rotor-to-end cover contact and the bearing housing inspected for signs of spacer-to-bore contact.

If the end covers have been damaged by rotor-to-end cover contact and there are grooves worn in more than .005" deep, the face should be resurfaced. If there is no damage, or the damage is minor, the face of the end cover should be wiped clean with solvent and then lapped with the lapping compound against the other end cover. Once complete the covers should be wiped, cleaned, and dried off with an air hose to remove any traces of lapping compound that could cause damage during assembly or start-up.

If the bearing housing bore is damaged, it can be cleaned up with a small file or 400 grit wet/dry sandpaper to remove any burrs. If either of the bearings had seized and spun in the housing, the fit should be checked with a new bearing, to ensure that there is not excessive clearance.

### **Oil Seal Replacement:**

The oil seals can be removed by inserting a screwdriver or punch through the shaft bore of the end cover on the oil seal to drive the seal out.

Place the new oil seal in the seal housing. Ensure that the oil seal is installed with the spring side of the seal facing into the bearing bore of the end cover.

---



**Note:** Incorrect installation of the oil seal will potentially result in oil leaks around the shaft and bearing failure.

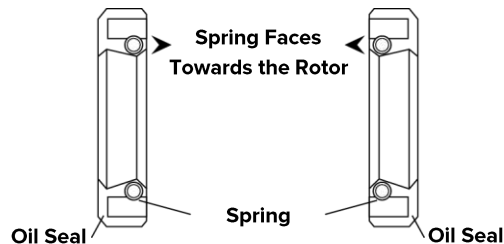

The oil seal should be pressed into the seal bore on the end cover using a seal press or a flat round disc approximately the same outside diameter as the oil seal. Care must be taken to press the oil seal into the bore evenly to prevent damage.

### **Reassembly:**

The area to be used for reassembly should be thoroughly cleaned to prevent contamination during the reassembly process.

### **Installing the First End Cover**

If both end covers have been removed from the cylinder the below procedure needs to be followed.

Spread a small amount of oil around the cylinder face to hold the end cover Shim Gaskets in place.

Place the new end cover Shim Gaskets (the correct quantity and color that were removed during the disassembly process) over the dowel pins and onto the oiled face of the cylinder.

Where used, install the O-Ring in the end cover groove. Small dabs of grease will help retain the O-Ring in the groove.

Align the end cover dowel pin holes with the dowel pins in the cylinder face. Drive the cover on evenly with a rubber mallet working from side-to-side to prevent bending the dowel pins or distorting the holes in the end cover.

Install the end cover retaining bolts and torque them to 29-30 ft/lbs. When tightening work across the cover, alternating from one side to the other to ensure even pressure.

Apply a small amount of grease to the lip of the oil seal.

### **Installing the Rotor Assembly:**

Spread vacuum pump oil around the cylinder bore to avoid damage to the rotor and cylinder bore when refitting the rotor.

For HXL Series pumps, reinstall the worm gear for the oil pump drive and tighten the set screw.

Inspect the ends of the rotor shaft to find the reference mark made during disassembly to ensure correct rotor-end cover-cylinder relationships. Once determined slip the rotor assembly into the cylinder and the bearing into the end cover bore. The bearing should slip in the cover house easily with only a slight tap with a rubber mallet. If the fit is extremely tight, the end cover bore should be examined for burrs and cleaned up. The bearing must be free to move slightly in and out of the cover bore without extreme force or damage to the pump will potentially occur.

Support the end of the shaft with the rotor support shaft used during disassembly.

### Installing the Vanes:

To install the vanes rotate the rotor so the free vane slot faces the bottom of the cylinder. Insert the new vane by sliding it along the cylinder wall. Be sure the vanes slide freely in the rotor.

Vanes for the H2, H3, HXL2 and HXL3 model pumps have a radiused edge. Install them with the radius in contact with the cylinder wall.

Vanes for the H1, HXL4 model pumps have an offset bevel. Install these vanes with the bevelled edge in contact with the cylinder wall and the leading edge facing in the direction of rotation.



**Note:** Make sure the vane is oriented correctly. The chamfered edges of the vane must be inserted into the rotor.

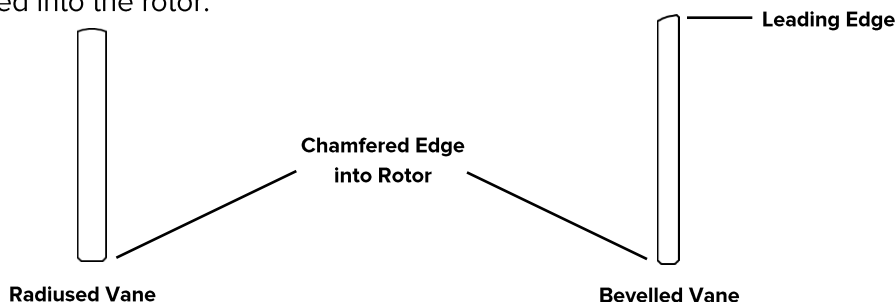

### Installing the End Cover:

Repeat the procedure of installing the first end cover until the O-ring (if used) has been fitted into the groove.

Apply a small amount of grease to the lip of the oil seal, remove the shaft support and fit the end cover over the end of the shaft. Lift the end cover and rotor assembly to align the dowel pins in the cylinder face and the end cover dowel pin holes. This procedure sets the seal gap between the rotor and the cylinder bore.

Once the pins are aligned, the cover can be driven against the cylinder face with a rubber mallet.

Install the end cover retaining bolts and torque them to 29-30 ft/lbs. When tightening work across the cover, alternating from one side to the other to ensure even pressure.

If the oil pump was removed, reinstall the drive assembly. Align the hole in the drive assembly with the oil inlet elbow and push the assembly in until it bottoms out. Engage the drive of the oil pump with the slot in the drive assembly and reinstall the oil pump. Prime the oil lines and reconnect the lines from the oil pump to the inlet fittings.

Reinstall the shaft cover and rotate the pump shaft by hand. If all is correct the rotor should turn freely at this point and the pump can be reinstalled on the system.



**Note:** If all is correct, you should be able to hear each vane drop and contact the cylinder as the rotor turns.

---

If the rotor does not turn freely, either one of the vanes is in crooked and caught on a bearing spacer or the rotor is jammed against one of the covers due to a bearing sticking in the housing. Before disassembling, strike the end of the rotor shaft with a rubber mallet and check for free rotation. It is possible for a bearing to become slightly stuck in the bore, or the rotor is tight against an end cover and will not turn due to lack of lubrication. If this does not cure the problem, disassemble the pump following the procedure for End Cover Removal detailed above.



**Note:** Be sure to lubricate the pump before initial start-up to prevent damage in the first few seconds of operation. Pour oil into the intake of the pump valve or into the cylinder oiling fittings and rotate by hand to distribute, and if fitted bleed the oil pump.

---

Before refitting the pump to the vacuum truck it is recommended that all of the system filters and traps are thoroughly cleaned and dried before the vacuum pump is operated.

## **Rebuild Specifications:**

### **Cylinder Remachining:**

If the cylinder scoring is deeper than .005" or if corrugation can be felt the cylinder should be bored, honed and the seal gap reset. In reboring the cylinder the aim is to remove the minimum level of material to achieve the original manufactured finish. Therefore the cylinder should only be machined down to the deepest scoring/corrugation.



**Note:** If the scoring/corrugation is deeper than the maximum remachining boring depth then the cylinder or pump will need to be replaced.

---

The cylinder remachining for each of the pumps should meet the specifications detailed in the table below:

Pump	Manufactured Diameter	Max Remachined Diameter	Honed Surface Finish
H1	4.72"	4.76"	0.4 $\mu\text{m}$
H2	6.77"	6.81"	1.6 $\mu\text{m}$
H3	6.77"	6.81"	1.6 $\mu\text{m}$
HXL2	6.77"	6.81"	1.6 $\mu\text{m}$
HXL3	6.77"	6.81"	1.6 $\mu\text{m}$
HXL4	5.98"	6.02"	0.4 $\mu\text{m}$



**Warning!** Do not exceed the maximum remachined diameter. By exceeding the maximum diameter it presents the risk of compromising both structural integrity and durability of the vacuum pump. Increased bore diameter will reduce vane support therefor reducing vane life and increases risk of vane breakage.

### Checking and Setting the Seal Gap Clearance:

If the cylinder has been rebored and/or honed the seal gap clearance needs to be checked and set as required.

The seal gap is the distance between the outer diameter of the rotor and the top of the inside of the cylinder bore. The seal gap is set at a certain specification to provide the maximum performance and efficiency.

The seal gap clearance for each of the pumps should meet the specifications in the table below:

Pump	Seal Gap	Tolerance
H1	0.0015"	+/-0.0005"
H2	0.0015"	+/-0.0005"
H3	0.0015"	+/-0.0005"
HXL2	0.0015"	+/-0.0005"
HXL3	0.0015"	+/-0.0005"
HXL4	0.003"	+/-0.0005"

This clearance can be checked by inserting the proper sized feeler gauge in the exhaust port of the pump across the top of the rotor to the inlet side of the pump.



**Note:** When checking the seal gap clearance the rotor should be turned so that none of the vane slots are at the top of the cylinder.

To accurately check the clearance this should be done at three points: in the center of the pump; and at each end of the rotor near the end cover. This will help ensure that the rotor is parallel with the cylinder bore.

If the clearance is within specification the dowel pins will not have to be refitted.

If the seal gap clearance needs to be reset the following technique can be used.



**Note:** In order to reset the seal gap clearance the dowel pins on the inlet side on both ends of the cylinder need to be removed.

- ▶ Place the correct sized feeler gauges in position in the cylinder
- ▶ Turn the pump upside down. For this to be possible the valve assembly will need to be removed to allow the cylinder to rest flat.
- ▶ Loosen the end cover bolts on both end covers
- ▶ Allow the end covers to pivot on the cylinders exhaust side dowel pins bringing the rotor into contact with the feeler gauges.
- ▶ Re-torque the end cover bolts evenly on both end covers
- ▶ Turn the pump over and re-check the seal gap clearance. Repeat the process if the seal gap clearance is still out of specification.
- ▶ If within specification drill and ream to fit either new oversized dowel pins or to reposition the original dowels pin.
- ▶ Clear swarf from the drilled holes and fit the dowel pins to secure the setting.

### Checking and Setting the End Float Clearance:

The end float clearance is the distance of travel between the end faces of the rotor and the end covers. The end clearance is set at a certain specification to provide the maximum performance and efficiency.

The end float clearance for each of the pumps should meet the specifications detailed in the table below:

Pump	End Float Minimum	End Float Maximum
H1	0.003"	0.005"
H2	0.003"	0.005"
H3	0.004"	0.006"
HX2	0.003"	0.005"
HXL3	0.004"	0.006"
HXL4	0.008"	0.010"

To set/check the end float clearance the following procedure should be used:



**Note:** The following procedure will require the use of a dial indicator and either a magnetic stand or a stand that can be bolted to one of the end cover bolts.

- ▶ Mount the dial indicator stand on the pump end cover and attach the Dial Indicator so that the end of the indicator is on the end of the pump shaft. The travel axis of the indicator must be on the same line as the axis of the pump shaft.
- ▶ Push the rotor firmly until it becomes tight against the end cover being set.



**Note:** In order to set /check the end float clearance correctly the three end thrust protection screws will need to be removed from each end cover.

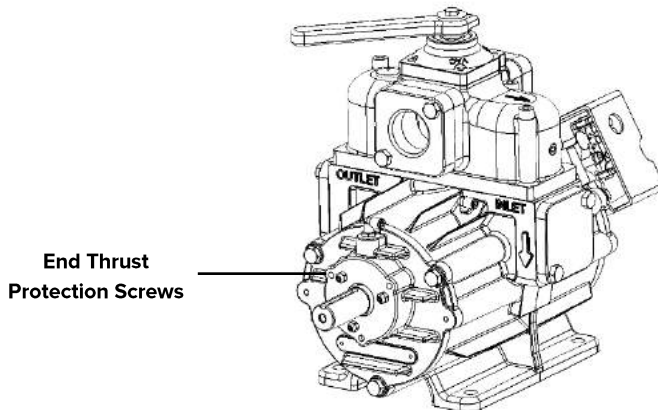

- ▶ Zero the Dial Indicator
- ▶ Push the rotor back firmly against the other end cover, and note the Dial Indicator reading
- ▶ The difference between the two readings is the total amount of end float. Check that the clearance value is within the range as specified in the table above.
- ▶ If the clearance is below the minimum an end cover will have to be removed and an end cover shim gaskets added to attain the proper clearance.
- ▶ If the clearance is above the maximum an end cover will have to be removed and an end cover shim gaskets removed to attain the proper clearance.
- ▶ If gaskets were added or subtracted, the above process will need to be repeated to changes made were correct and the pump is within specification.

### **Setting the End Thrust Protection:**

Thrust screws are fitted into the end cover of the Masport HXL Series pumps. These thrust screws limit the travel of the rotor between the end covers, reducing the risk of rotor to end cover contact. This allows the pump to be direct couple driven without damage to the rotors or covers from lateral thrust loads produced by the drive system.

The end thrust protection for each of the pumps should meet the specifications detailed in the table below:

Pump	End Thrust	Tolerance
H1	0.001"	+/-0.0005"
H2	0.001"	+/-0.0005"
H3	0.001"	+/-0.0005"
HXL2	0.001"	+/-0.0005"
HXL3	0.001"	+/-0.0005"
HXL4	0.002"	+/-0.0005"

To set the end thrust protection the following procedure should be used:



**Note:** The following procedure will require the use of a dial indicator and either a magnetic stand or a stand that can be bolted to one of the end cover bolts.

- ▶ Position the pump horizontally.
- ▶ Fit three thrust screws with lock nuts to one of the end covers. Apply Loctite 567 thread sealant to thrust screws prior to screwing in.



**Warning!** Do not place any sealant directly into the tapped holes in the end cover. This could result in bearing contamination.

- ▶ Mount the dial indicator stand on the pump end cover and attach the Dial Indicator so that the end of the indicator is on the end of the pump shaft. The travel axis of the indicator must be on the same line as the axis of the pump shaft.
- ▶ Push the rotor firmly until it becomes tight against the end cover being set.
- ▶ Zero the Dial Indicator
- ▶ Tighten the three thrust screws until they just touch the bearing race. This will be indicated by the Dial Indicator needle starting to move off zero.
- ▶ Once the thrust screw are in contact with the bearing tighten them progressively to move the rotor off the cover by the value as specified in the table above.



**Note:** Make the first adjustments of 0.0005" Dial indicator movement for each screw. Then make small fractional adjustments of the balance until the total adjustment setting is reached. The last 0.0005" of adjustment should be broken into several small adjustments shared progressively across all three thrust screws.

- ▶ Tighten the lock nuts ensuring the thrust screw does not move and that there is no movement on the dial of the Dial Indicator.



- ▶ Repeat the process on the thrust screws on the other end of the pump.
- ▶ If the vanes had been left out for setting remove an end cover and refit the vanes and end cover.

## Exploded Views

### H1F:

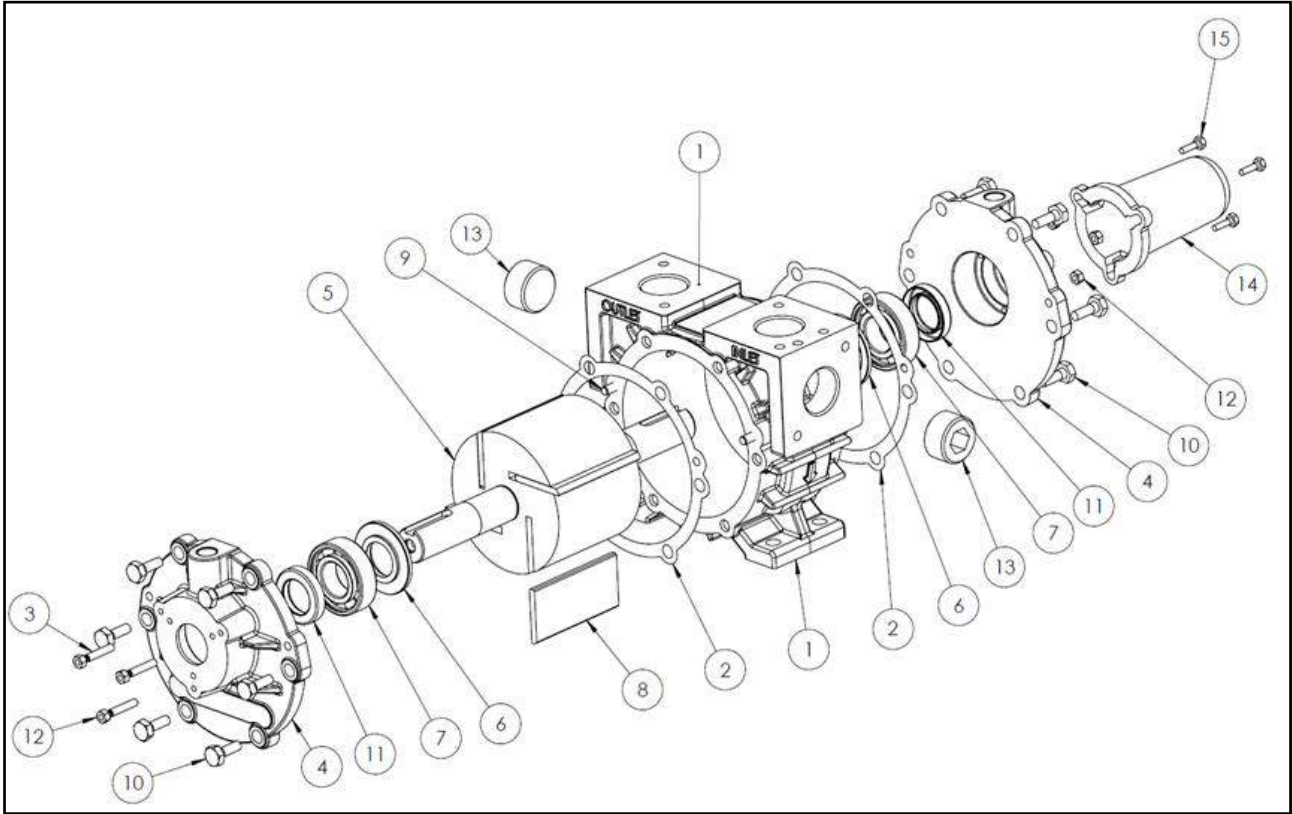

Item	Description	Part No.	Qty
1	Cylinder	968111	1
2	Shim Gasket 0.002"	575024	*
3	Grub Screw M5 x 20	503225	6
4	End Cover	968109	2
5	Rotor Assembly	968154	1
6	Spacer	975109	2
7	Bearing	501574	2
8	Vane Pack	968217	4

Item	Description	Part No.	Qty
9	Dowel Pin	575111	4
10	Screw M8 x 30	501848	12
11	Seal	501578	2
12	Nut M5	220221	6
13	Plug	501679	2
14	Shaft Guard	675264	1
15	Screw M5 x 26	503227	3

\* Quantity may vary pump to pump

**H2F:**

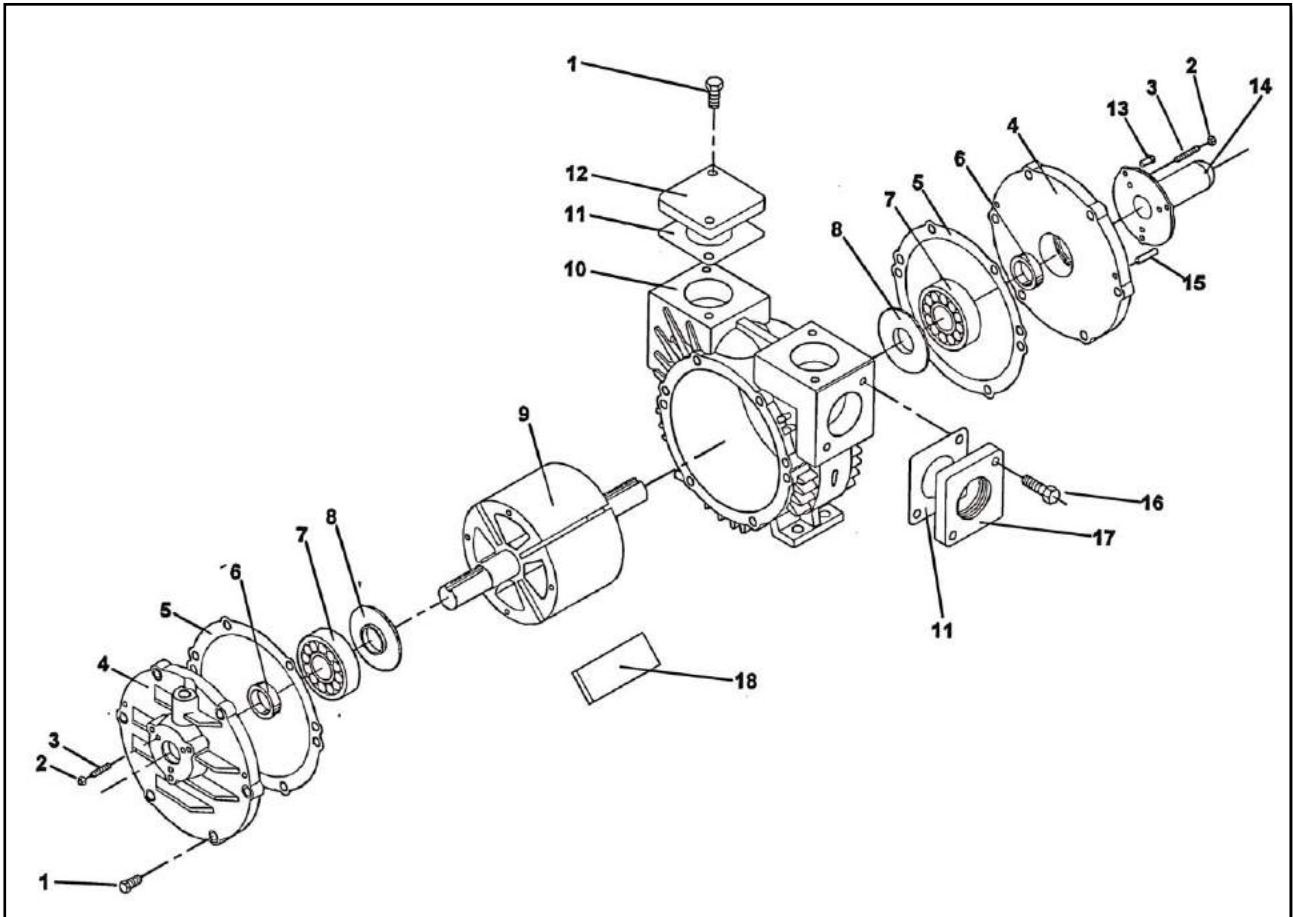

Item	Description	Part No.	Qty
1	Screw M10 x 25	501569	16
2	Nut M5	220221	6
3	Grub Screw M5 x 25	503225	6
4	End Cover	968242	2
5	Shim Gasket 0.001"	575006	*
	0.002"	575007	*
6	Seal	501578	2
7	Bearing	501577	2
8	Spacer	575131	2
9	Rotor Assembly	968124	1

Item	Description	Part No.	Qty
10	Cylinder	975541	1
11	Flange Gasket	36202	4
12	Flange Blank	975487	2
13	Screw M5 x 16	503227	3
14	Shaft Guard	975264	1
15	Dowel Pin	575111	4
16	Screw M10 x 35	501878	4
17	Flange 1 1/2"	968204	2
18	Vane Pack	975536	4

\* Quantity may vary pump to pump

**H3F:**

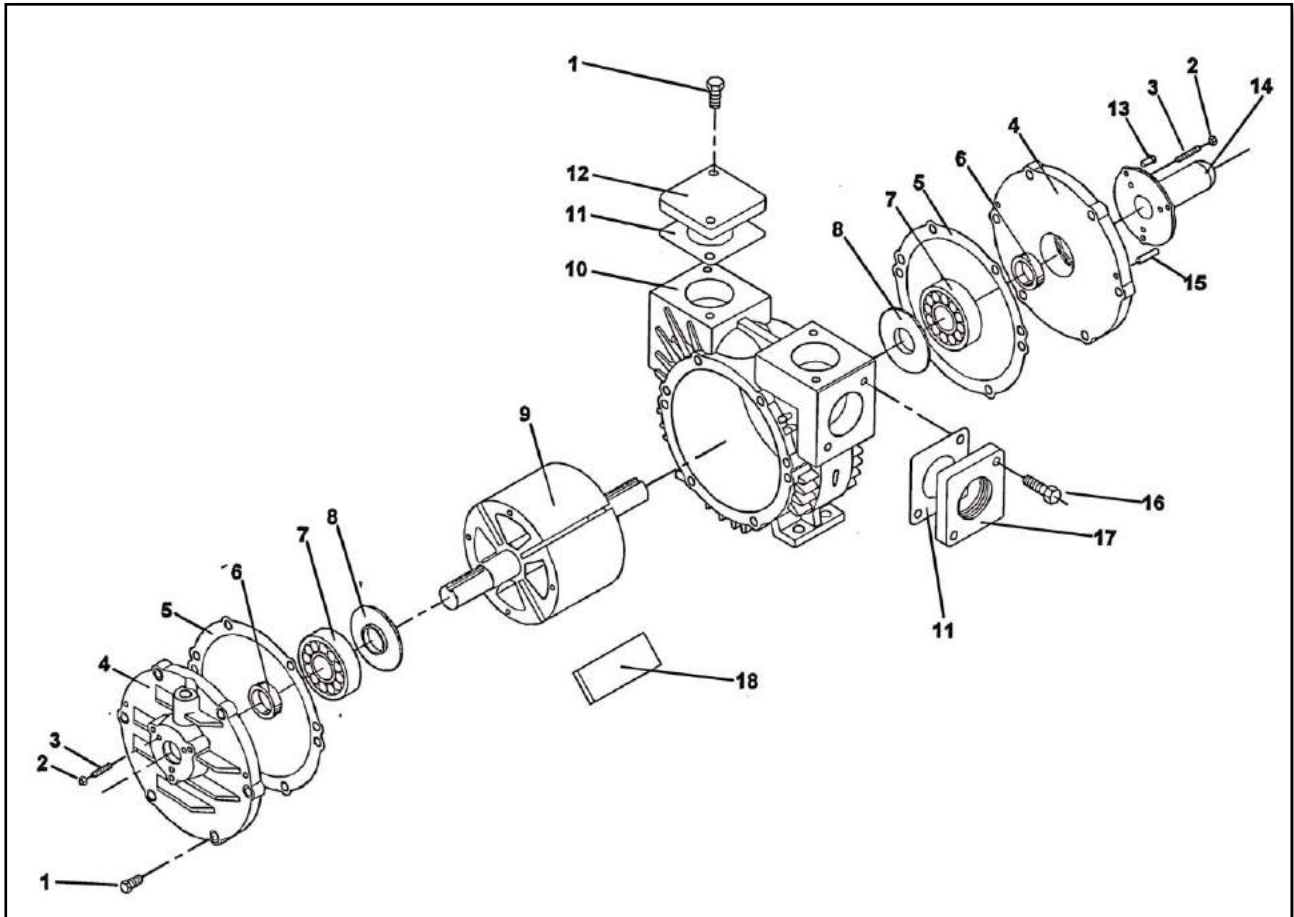

Item	Description	Part No.	Qty
1	Screw M10 x 25	501569	16
2	Nut M5	220221	6
3	Grub Screw M5 x 25	503225	6
4	End Cover	968242	2
5	Shim Gasket 0.001"	575006	*
	0.002"	575007	*
6	Seal	501578	2
7	Bearing	501577	2
8	Spacer	575131	2
9	Rotor Assembly	968244	1

Item	Description	Part No.	Qty
10	Cylinder	975551	1
11	Flange Gasket	36202	4
12	Flange Blank	975487	2
13	Screw M5 x 16	503227	3
14	Shaft Guard	975264	1
15	Dowel Pin	575111	4
16	Screw M10 x 35	501878	4
17	Flange 1 1/2"	968204	2
18	Vane Pack	968236	4

\* Quantity may vary pump to pump

**HXL2F – Serial Number Q06128 and Greater.**

*Bearing and Oil Pump End Cover Changed at Q06128*

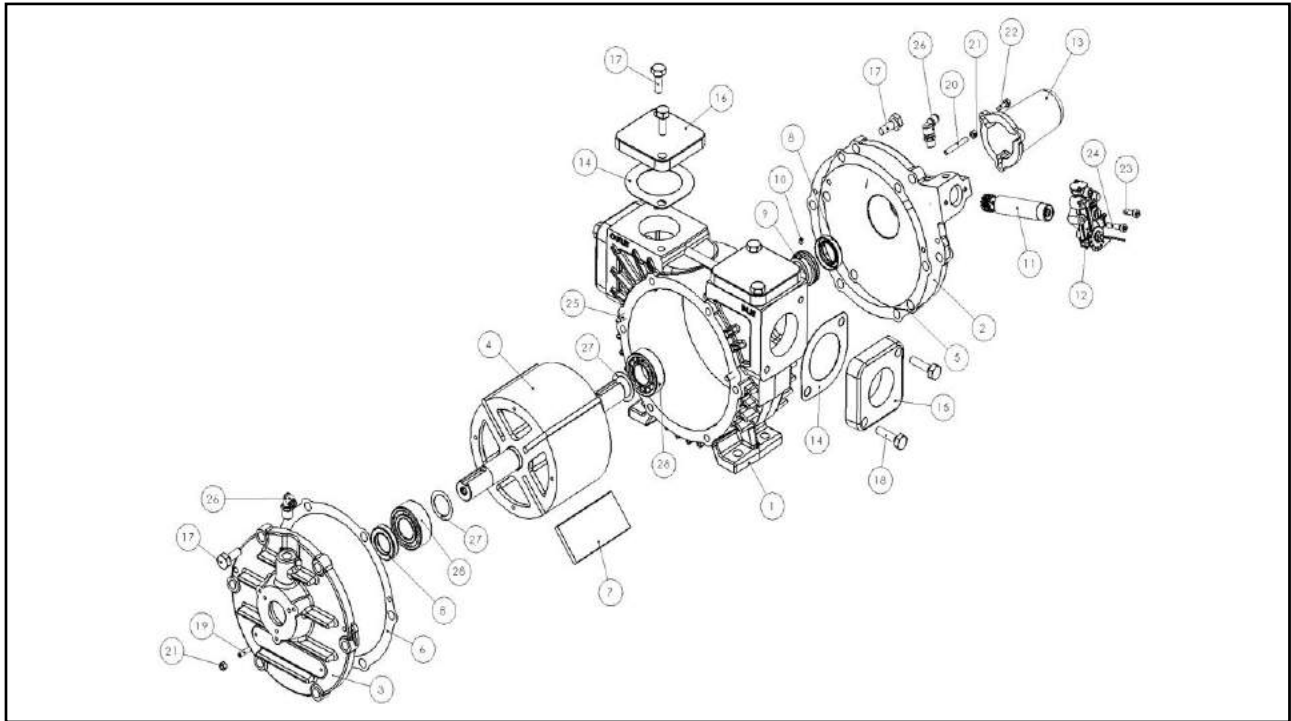

Item	Description	Part No.	Qty
1	Cylinder	975541	1
2	End Cover Oil Pump	969201	1
3	End Cover	968242	1
4	Rotor Assembly	968126	1
5	Shim Gasket 0.001"	575005	1
6	Shim Gasket 0.002"	575006	1
7	Vane Pack	975536	1
8	Seal	501578	2
9	Gear Worm	568071	1
10	Grub Screw M5 x 6	504264	1
11	Gear Shaft Assembly	968045	1
12	Oil Pump	575366	1
13	Shaft Guard	675264	1
14	Flange Gasket	36202	4
15	Flange 1 ½"	968159	2

Item	Description	Part No.	Qty
16	Flange Blank	975476	2
17	Screw M10 x 25	501569	16
18	Screw M10 x 35	501878	4
19	Grub Screw M5 x 20	503225	3
20	Grub Screw M5 x 40	503226	3
21	Nut M5	220221	6
22	Screw M5 x 16	503227	3
23	Screw M5 x 16	504262	1
24	Screw M5 x 25	504261	1
25	Dowel Pin	575111	4
26	Elbow Swivel 1/4" **	568086	2
27	Spacer	575131	2
28	Bearing	501577	2
29	Oil Line (Not Shown)	600293	*

\* Quantity may vary pump to pump

\*\* Pre-Serial Number P07044: Item 26 was 1 x 568086 - Elbow Swivel 1/4" & 1 x 568085 - Elbow Swivel 1/8"

**HXL2V – Serial Number Q06128 and Greater.**

*Bearing and Oil Pump End Cover Changed at Q06128*

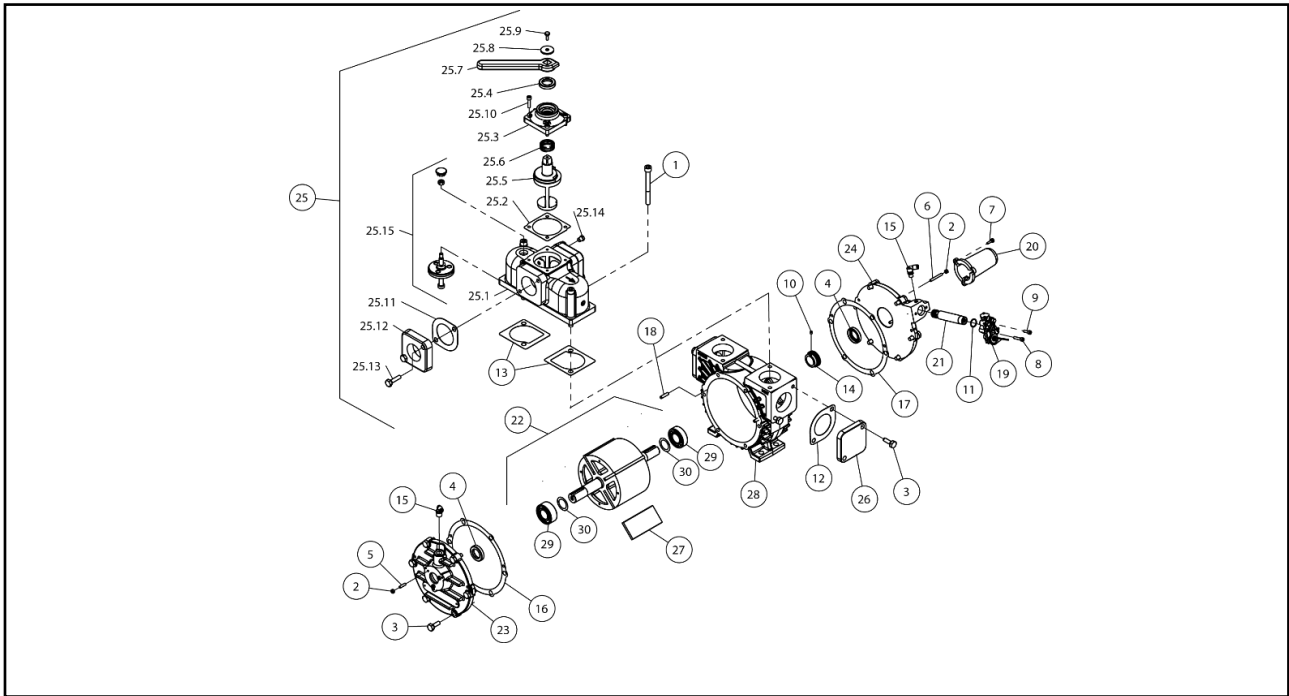

Item	Description	Part No.	Qty
1	Screw M10 x 100	568249	4
2	Nut M5	220221	6
3	Screw M10 x 25	501569	16
4	Seal	501578	2
5	Screw M5 x 20	503225	3
6	Screw M5 x 40	503226	3
7	Screw M5 x 16	503227	3
8	Screw M5 x 25	504261	1
9	Screw M5 x 16	504262	1
10	Grub Screw M5 x 6	504264	1
11	O-Ring	504265	1
12	Flange Gasket	36202	2
13	Valve Gasket	568066	2
14	Gear Worm	568071	1
15	Elbow Swivel 1/4" **	568086	2
16	Shim Gasket 0.002"	575006	*
17	Shim Gasket 0.003"	575007	*
18	Dowel Pin	575111	4
19	Oil Pump	575366	1
20	Shaft Guard	675264	1
21	Drive Shaft Assembly	968045	1
22	Rotor Assembly	968126	1
23	End Cover	968242	1

Item	Description	Part No.	Qty
24	End Cover Oil Pump	969201	1
25	Valve Assembly	968350	1
25.1	Valve Body	968349	1
25.2	Valve Cap Gasket	568063	1
25.3	Valve Cap	968346	1
25.4	Seal	501578	1
25.5	Valve Spool	968341	1
25.6	Spool Spring	568347	1
25.7	Valve Handle	968055	1
25.8	Indicator Washer	569724	1
25.9	Screw M8 x 20	501848	1
25.10	Screw M6 x 25	11049	4
25.11	Flange Gasket	568009	2
25.12	Flange 1 1/2"	968159	2
25.13	Screw M10 x 35	501878	4
25.14	Plug 1/8"	143901	1
25.15	Poppet Assembly	968351	1
26	Flange Blank	975476	2
27	Vane Pack	975536	1
28	Cylinder	975536	1
29	Bearing	501577	2
30	Spacer	575131	2
31	Oil Line (Not Shown)	600293	1

\* Quantity may vary pump to pump

\*\* Pre-Serial Number P07044: Item 15 was 1 x 568086 - Elbow Swivel 1/4" & 1 x 568085 - Elbow Swivel 1/8"

## HXL3F – Serial Number Q07076 and Greater:

Bearing and Oil Pump End Cover Changed at Q07076

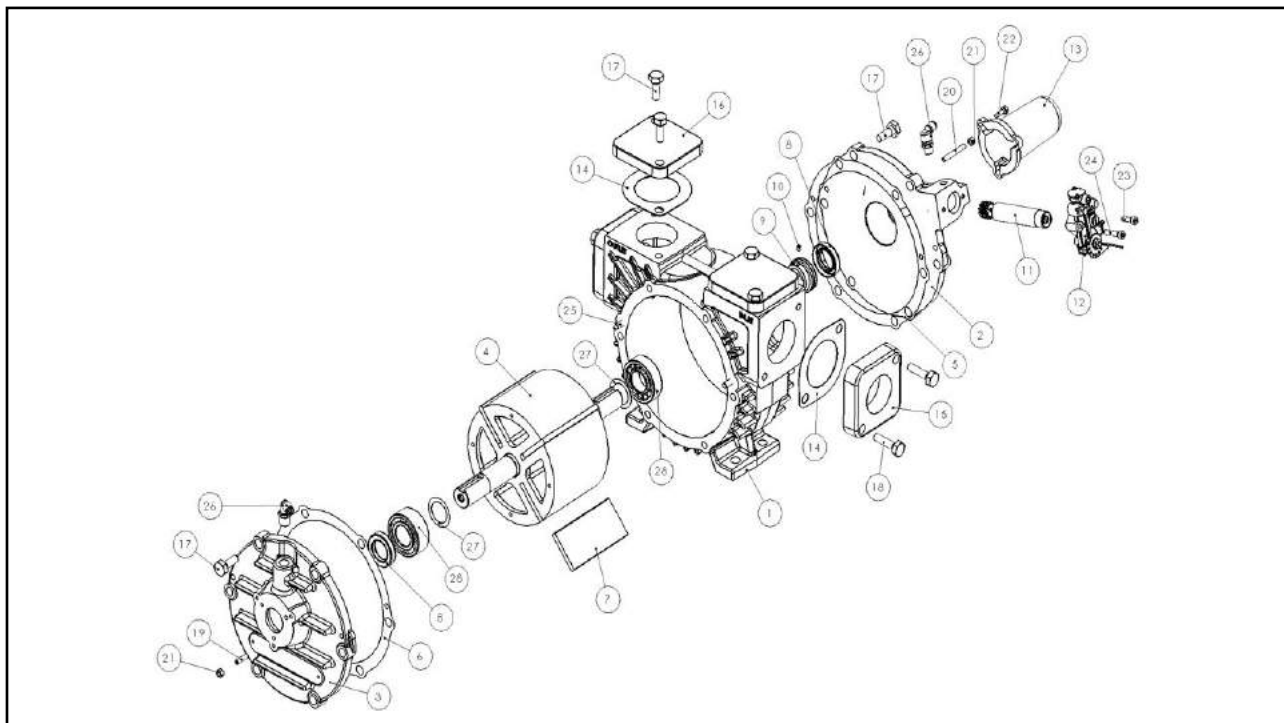

Item	Description	Part No.	Qty
1	Cylinder	975551	1
2	End Cover Oil Pump	969201	1
3	End Cover	968242	1
4	Rotor Assembly	975254	1
5	Shim Gasket 0.001"	575005	1
6	Shim Gasket 0.002"	575006	1
7	Vane Pack	968236	1
8	Seal	501578	2
9	Gear Worm	568071	1
10	Grub Screw M5 x 6	504264	1
11	Gear Shaft Assembly	968045	1
12	Oil Pump	57366	1
13	Shaft Guard	675264	1
14	Flange Gasket	36202	4
15	Flange 1 ½"	968159	2

Item	Description	Part No.	Qty
16	Flange Blank	975476	2
17	Screw M10 x 25	501569	16
18	Screw M10 x 35	501878	4
19	Grub Screw M5 x 20	503225	3
20	Grub Screw M5 x 40	503226	3
21	Nut M5	220221	6
22	Screw M5 x 16	503227	3
23	Screw M5 x 16	504262	1
24	Screw M5 x 25	504261	1
25	Dowel Pin	575111	4
26	Elbow Swivel 1/4" **	568086	2
27	Spacer	575131	2
28	Bearing	501577	2
29	Oil Line (Not Shown)	600293	1

\* Quantity may vary pump to pump

\*\* Pre-Serial Number P07044: Item 26 was 1 x 568086 - Elbow Swivel 1/4" & 1 x 568085 - Elbow Swivel 1/8"

**HXL3V – Serial Number Q07076 and Greater:**

*Bearing and Oil Pump End Cover Changed at Q07076*

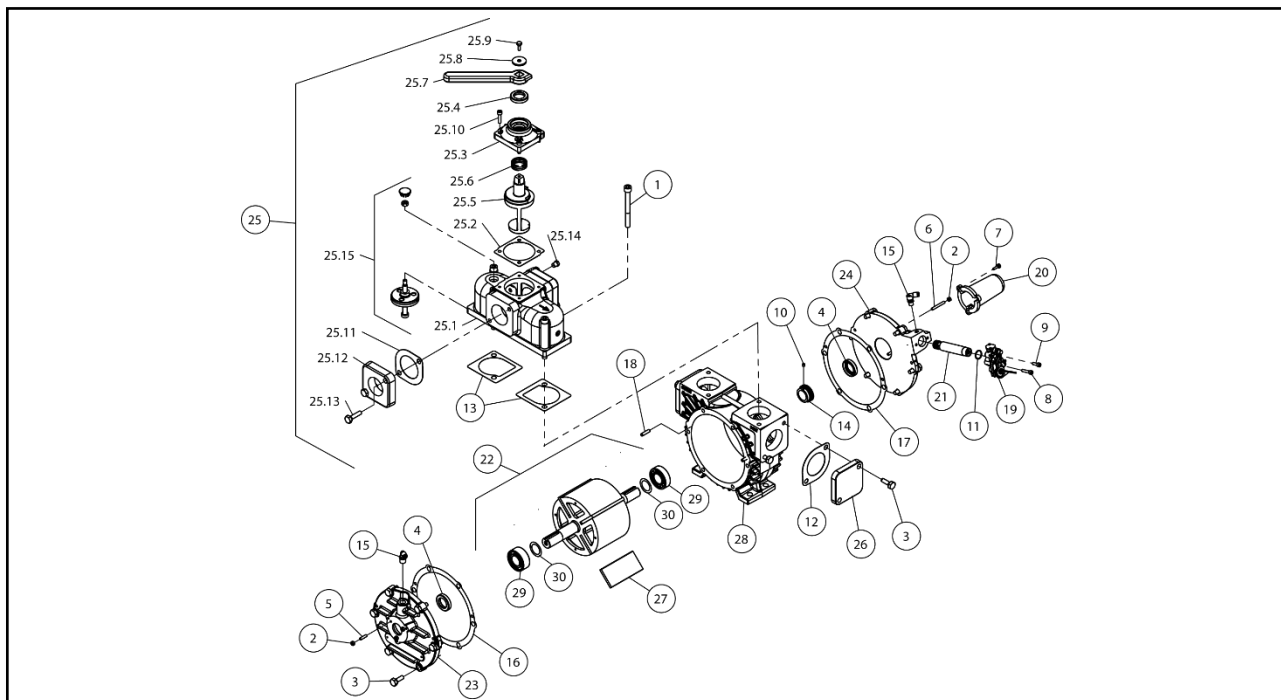

Item	Description	Part No.	Qty
1	Screw M10 x 100	568249	4
2	Nut M5	220221	6
3	Screw M10 x 25	501569	16
4	Seal	501578	2
5	Screw M5 x 20	503225	3
6	Screw M5 x 40	503226	3
7	Screw M5 x 16	503227	3
8	Screw M5 x 25	504261	1
9	Screw M5 x 16	504262	1
10	Grub Screw M5 x 6	504264	1
11	O-Ring	504265	1
12	Flange Gasket	36202	2
13	Valve Gasket	568066	2
14	Gear Worm	568071	1
15	Elbow Swivel 1/4" **	568086	2
16	Shim Gasket 0.002"	575006	*
17	Shim Gasket 0.003"	575007	*
18	Dowel Pin	575111	4
19	Oil Pump	575366	1
20	Shaft Guard	675264	1
21	Drive Shaft Assembly	968045	1
22	Rotor Assembly	968246	1
23	End Cover	968242	1

Item	Description	Part No.	Qty
24	End Cover Oil Pump	969201	1
25	Valve Assembly	968350	1
25.1	Valve Body	968349	1
25.2	Valve Cap Gasket	568063	1
25.3	Valve Cap	968346	1
25.4	Seal	501578	1
25.5	Valve Spool	968341	1
25.6	Spool Spring	568347	1
25.7	Valve Handle	968055	1
25.8	Indicator Washer	569724	1
25.9	Screw M8 x 20	501848	1
25.10	Screw M6 x 25	11049	4
25.11	Flange Gasket	568009	2
25.12	Flange 1 1/2"	968159	2
25.13	Screw M10 x 35	501878	4
25.14	Plug 1/8"	143901	1
25.15	Poppet Assembly	968351	1
26	Flange Blank	975476	2
27	Vane Pack	968236	1
28	Cylinder	975551	1
29	Bearing	501577	2
30	Spacer	575131	2
31	Oil Line (Not Shown)	600293	1

\* Quantity may vary pump to pump

\*\* Pre-Serial Number P07044: Item 15 was 1 x 568086 - Elbow Swivel 1/4" & 1 x 568085 - Elbow Swivel 1/8"



**HXL4F:**

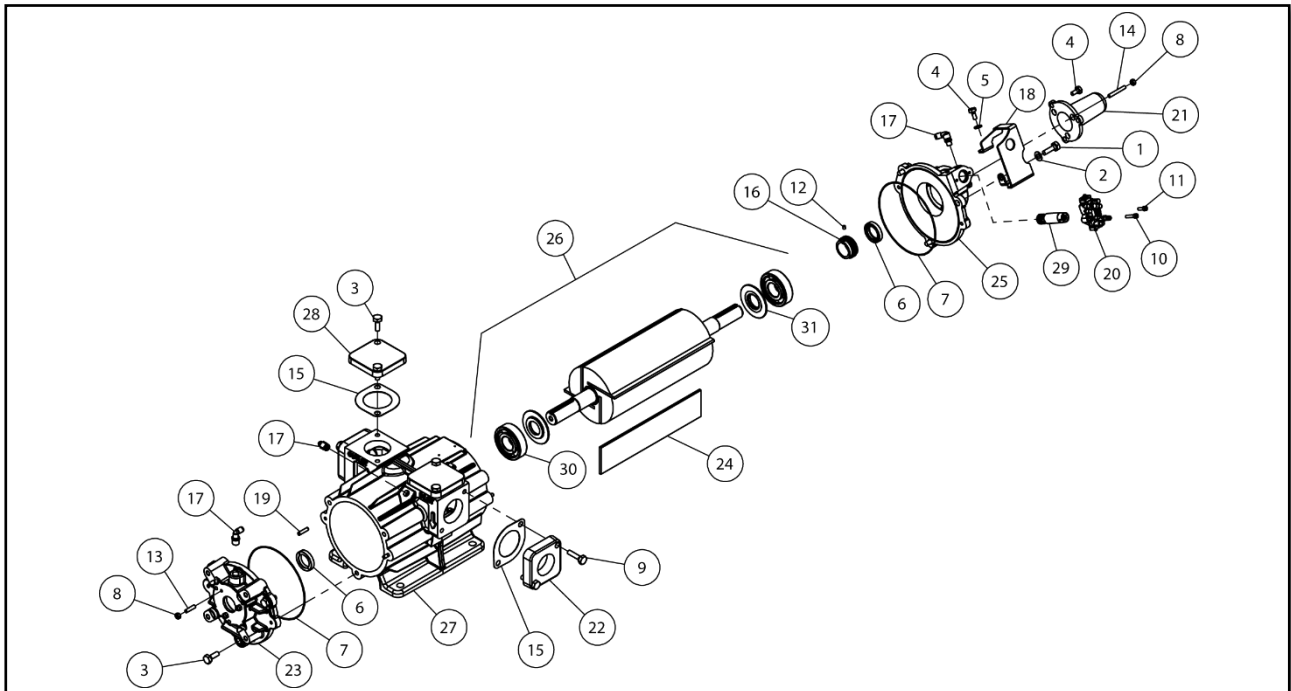

Item	Description	Part No.	Qty
1	Screw M10 x 30	32307	1
2	Washer 3/8"	32508	1
3	Screw M10 x 25	501569	9
4	Screw M8 x 16	501571	4
5	Lockwasher M8	501610	1
6	Seal	501681	2
7	O-Ring	501004	2
8	Nut M6	501682	6
9	Screw M10 x 35	501878	4
10	Screw M5 x 25	504261	1
11	Screw M5 x 16	504262	1
12	Screw M5 x 6	504264	1
13	Screw M6 x 25	504274	3
14	Screw M6 x 45	504275	3
15	Flange Gasket	36202	4
16	Gear Worm	568069	1
17	Elbow Swivel 1/4" **	568086	4

Item	Description	Part No.	Qty
18	Oil Pump Guard	568904	1
19	Dowel Pin	575111	4
20	Oil Pump	575437	1
21	Shaft Guard	961412	1
22	Flange 1 1/2"	968159	2
23	End Cover	969761	1
24	Vane Pack	975393	4
25	End Cover Oil Pump	975468	1
26	Rotor Assembly	975469	1
27	Cylinder	975471	1
28	Flange Blank	975476	2
29	Drive Shaft Assembly	975482	1
30	Bearing	500082	2
31	Spacer	975496	2
32	Shim Gasket (Not Shown)	575248	*
33	Oil Line (Not shown)	600293	1

\* Quantity may vary pump to pump

\*\* Pre-Serial Number Q09033: Item 17 was 3 x 568086 - Elbow Swivel 1/4" & 1 x 568085 - Elbow Swivel 1/8"

**HXL4V:**

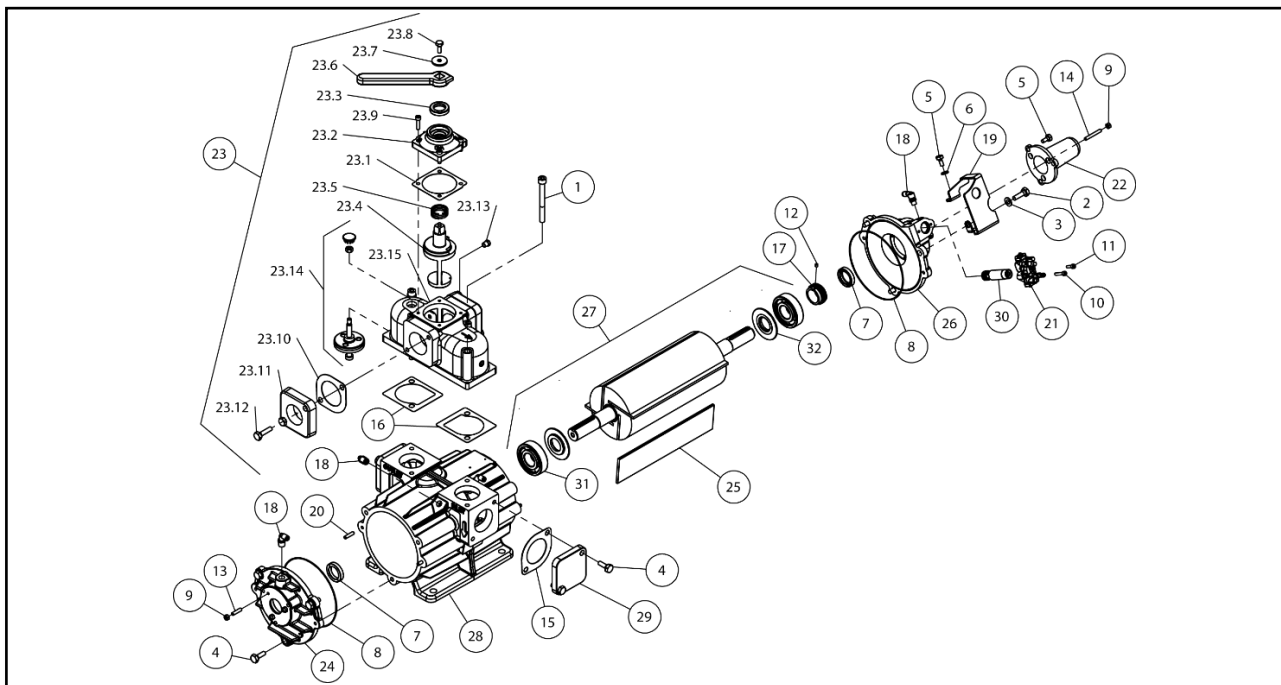

Item	Description	Part No.	Qty
1	Screw M10 x 100	568249	4
2	Screw M10 x 30	32307	1
3	Washer 3/8"	32508	1
4	Screw M10 x 25	501569	9
5	Screw M8 x 16	501571	4
6	Lockwasher M8	501610	1
7	Seal	501676	2
8	O-Ring	501681	2
9	Nut M6	501682	6
10	Screw M5 x 25	504261	1
11	Screw M5 x 16	504262	1
12	Screw M5 x 6	504264	1
13	Screw M6 x 25	504274	3
14	Screw M6 x 45	504275	3
15	Flange Gasket	36202	2
16	Valve Gasket	568066	2
17	Gear Worm	568069	1
18	Elbow Swivel 1/4" **	568086	4
19	Oli Pump Guard	568904	1
20	Dowel Pin	575111	4
21	Oil Pump	575437	1
22	Shaft Guard	961412	1
23	Valve Assembly	968350	1
23.1	Valve Cap Gasket	568063	1
23.2	Valve Cap	968346	1

Item	Description	Part No.	Qty
23.3	Seal	501578	1
23.4	Valve Spool	968341	1
23.5	Spool Spring	568347	1
23.6	Valve Handle	968055	1
23.7	Indicator Washer	569724	1
23.8	Screw M8 x 20	501848	1
23.9	Screw M6 x 25	11049	4
23.10	Flange Gasket	36202	2
24.1	Flange 1 1/2"	968159	2
23.12	Screw M10 x 35	501878	4
23.13	Plug 1/8"	143901	1
23.14	Poppet Assembly	968351	1
23.15	Valve Body	968349	1
24	End Cover	969761	1
25	Vane Pack	975393	1
26	End Cover Oil Pump	975468	1
27	Rotor Assembly	975469	1
28	Cylinder	975471	1
29	Flange Blank	975476	2
30	Drive Shaft Assembly	975482	1
31	Bearing	500082	2
32	Spacer	975496	2
33	Shim Gasket (Not Shown)	575248	*
34	Oil Line (Not Shown)	600293	1

\* Quantity may vary pump to pump

\*\* Pre-Serial Number Q09033: Item 18 was 3 x 568086 - Elbow Swivel 1/4" and 1 x 568085 - Elbow Swivel 1/8"

**Remote Lubricator – For H Series Pumps**

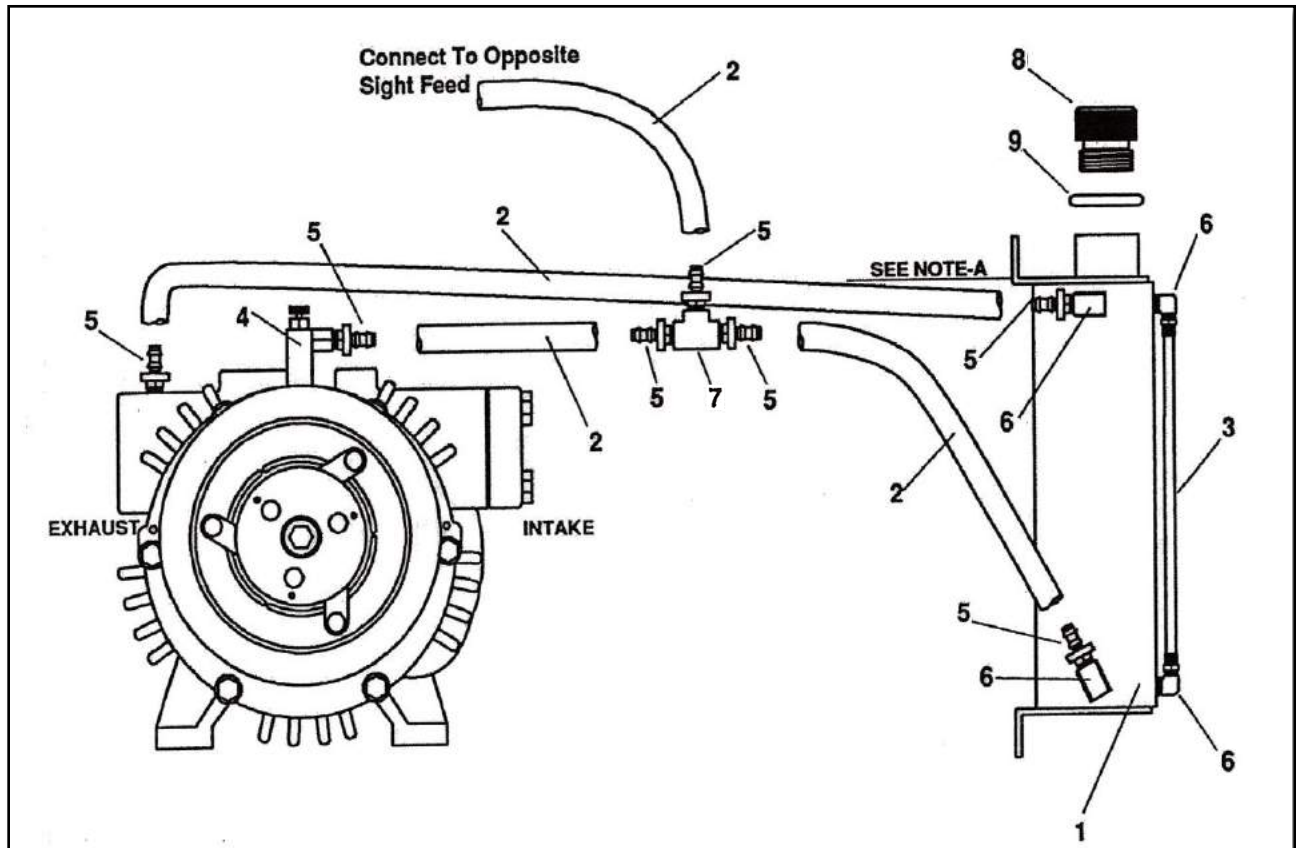

Item	Description	Part No.	Qty
1	Oil Reservoir	18058	1
2	Push Lock Hose 1/4"	24299	15
3	Poly Tubing 1/4" ID	24294	8
4	Sight Feed	25303	2
5	Brass Push Lock 1/8"	27003	6

Item	Description	Part No.	Qty
6	1/8" x 1/4" Tube Adaptor	27051	4
7	Brass Tee 1/8"	27022	1
8	Oil Reservoir Cap	27200	1
9	O-Ring for Oil Cap	36112	1

# MASPORT

VACUUM PUMP SYSTEMS

6801 Cornhusker Highway, Lincoln NE, 68507, USA

Toll Free: 800-228-4510 | Phone: 402-466-8355 | Email: [cs@masportpump.com](mailto:cs@masportpump.com)

[www.masportpump.com](http://www.masportpump.com)